

OWNER'S/ OPERATOR'S MANUAL

MODEL NO.'s

BSF-1523

BSF-122

DBFS-30

BSFA-20



CAUTION

For Safe Operation
Read Rules And
Instructions Carefully

SINO LEEINGLES, PIDA AYUDA
A AIGUIEN QUE SI LO LEA
PARA QUE LE TRADUZCA LAS
MEDIDAS DE SEGURIDAD.

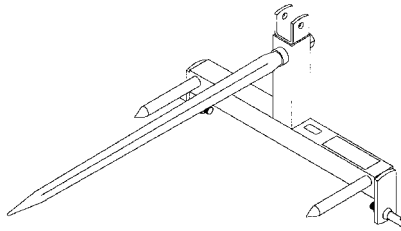

BSF-1523

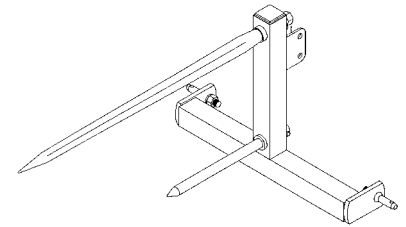

BSF-122

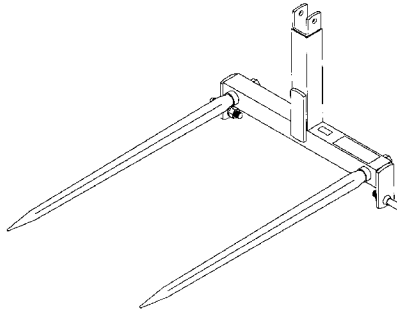

DBFS-30

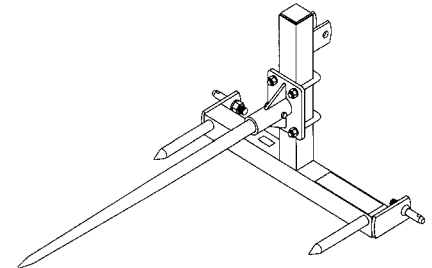

BSFA-20

3 PT. HITCH BALE SPEARS

**Safety Instructions
Assembly & Mounting
Operating Instructions**

**Maintenance
Repair Parts**

CAUTION

**THE FOLLOWING SAFETY PRECAUTIONS SHOULD BE THOROUGHLY UNDERSTOOD
BEFORE ATTEMPTING TO BEGIN ASSEMBLING THIS MACHINE**

1. Select an area for assembly that is clean and free of any debris which might cause persons working on the assembly to trip.
2. Do not lift heavy parts or assemblies. Use crane, jack, tackle, fork trucks or other mechanical devices.
3. Preview the assembly instructions in your operator's manual before proceeding further.
4. If the assembly instructions call for parts or assemblies to be blocked up, use only blocking material that is in good condition and is capable of handling the weight of the assembly to be blocked. Also insure that the blocking material is on a clean, dry surface.
5. Never put hands, or any part of body, under blocked up assemblies if at all possible.
6. After completing assembly, thoroughly inspect the machine to be sure that all nuts, bolts, hydraulic fittings or any other fastened assemblies have been thoroughly tightened.
7. Before operating the machine, thoroughly read the operation section of your operator's manual.
8. Before operating, read the maintenance section of your operator's manual to be sure that any parts requiring lubrication, such as gearboxes, are full, to avoid any possible damage.
9. **Before operating equipment – If you have any questions regarding the proper assembly or operation, contact your dealer or representative.**

To the Owner/Operator/Dealer

All implements with moving parts are potentially hazardous. There is no substitute for a cautious, safe-minded operator who recognizes the potential hazards and follows reasonable safety practices. The manufacturer has designed this implement to be used with all its safety equipment properly attached to minimize the chance of accidents.

BEFORE YOU START!!

Read the safety messages on the implement and shown in your manual.
Observe the rules of safety and common sense!



THIS SYMBOL MEANS

- ATTENTION!
- BECOME ALERT!
- YOUR SAFETY IS INVOLVED!

THIS SAFETY ALERT SYMBOL IDENTIFIES IMPORTANT SAFETY WARNING MESSAGES. CAREFULLY READ EACH WARNING MESSAGE THAT FOLLOWS. FAILURE TO UNDERSTAND AND OBEY A SAFETY WARNING, OR RECOGNIZE A SAFETY HAZARD, COULD RESULT IN AN INJURY OR DEATH TO YOU OR OTHERS AROUND YOU. THE OPERATOR IS ULTIMATELY RESPONSIBLE FOR THE SAFETY OF HIMSELF, AS WELL AS OTHERS, IN THE OPERATING AREA OF THE TRACTOR AND ATTACHED EQUIPMENT.

UNDERSTAND SIGNAL WORDS

Note the use of the signal words **DANGER**, **WARNING** and **CAUTION** with the safety messages. The appropriate signal word for each has been selected using the following guidelines:

DANGER: Indicates an imminently hazardous situation that, if not avoided, will result in death or serious injury. This signal word is to be limited to the most extreme situations typically for machine components which, for functional purposes, cannot be guarded.

WARNING: Indicates a potentially hazardous situation that, if not avoided, could result in death or serious injury, and includes hazards that are exposed when guards are removed. It may also be used to alert against unsafe practices.

CAUTION: Indicates a potentially hazardous situation that, if not avoided, may result in minor or moderate injury. It may also be used to alert against unsafe practices.

If you have questions not answered in this manual or require additional copies or the manual is damaged, please contact your dealer or the manufacturer directly.

IMPORTANT SAFETY INFORMATION!

Working with unfamiliar equipment can lead to careless injuries. Read this manual, and the manual for your tractor, before assembly or operating, to acquaint yourself with the machines. It is the implement owner's responsibility, if this machine is used by any person other than yourself, is loaned or rented, to make certain that the operator, prior to operating:

1. Reads and understands the operator's manuals.
2. Is instructed in safe and proper use.









The use of this equipment is subject to certain hazards which cannot be protected against by mechanical means or product design. All operators of this equipment must read and understand this entire manual, paying particular attention to safety and operating instructions, prior to using. If there is something in this manual you do not understand, ask your supervisor, or your dealer, to explain it to you.

SAFETY INSTRUCTIONS (continued)







EQUIPMENT SAFETY GUIDELINES



-  Never use alcoholic beverages or drugs which can hinder alertness or coordination while operating this equipment. Consult your doctor about operating this machine while taking prescription medications.
-  Review the safety instructions with all users annually.
-  This equipment is dangerous to children and persons unfamiliar with its operation. The operator should be a responsible adult familiar with farm machinery and trained in this equipment's operations. **Do not allow persons to operate or assemble this unit until they have read this manual and have developed a thorough understanding of the safety precautions and of how it works.**
-  To prevent injury or death, use a tractor equipped with a Roll-Over Protective System (ROPS). Do not paint over, remove or deface any safety signs or warning signs on your equipment. Observe all safety signs and practice the instruction on them.
-  Never exceed the limits of a piece of machinery. If its ability to do a job, or to do so safely, is in question – **DON'T TRY IT.**
-  Do not modify the equipment in any way. Unauthorized modification may impair the function and/or safety and could affect the life of the equipment.
-  In addition to the design and configuration of this implement, including Safety Signs and Safety Equipment, hazard control and accident prevention are dependent upon the awareness, concern, prudence, and proper training of personnel involved in the operation, transport, maintenance, and storage of the machine. Refer also to Safety Messages and Operation Instructions in each of the appropriate sections of the Tractor and Implement Manuals. Pay close attention to the Safety Signs affixed to the Tractor and the Implement.



SAFETY SIGNS

-  Keep safety signs clean and legible at all times.
-  Replace safety signs that are missing or have become illegible.
-  Replaced parts that displayed a safety sign should also display the current sign.
-  Safety signs are available from your Distributor or Dealer Parts Department or the factory.

How to Install Safety Signs:

-  Be sure that the installation area is clean and dry.
-  Be sure temperature is above 50°F (10°C).

SAFETY INSTRUCTIONS (continued)

How to Install Safety Signs (continued):



Decide on the exact position before you remove the backing paper.



Remove the smallest portion of the split backing paper.



Align the sign over the specified area and carefully press the small portion with the exposed sticky backing in place.



Slowly peel back the remaining paper and carefully smooth the remaining portion of the sign in place.



Small air pockets can be pierced with a pin and smoothed out using the piece of sign backing paper.



SAFETY TRAINING



Safety is a primary concern in the design and manufacture of our products. Unfortunately, our efforts to provide safe equipment can be wiped out by a single careless act of an operator.



In addition to the design and configuration of equipment, hazard control and accident prevention are dependent upon the awareness, concern, prudence and proper training of personnel involved in the operation, transport, maintenance and storage of equipment.



It has been said, "The best safety device is an informed, careful operator." We ask you to be that kind of an operator. It is the operator's responsibility to read and understand ALL Safety and Operating instructions in the manual and to follow these. Accidents can be avoided.



Working with unfamiliar equipment can lead to careless injuries. Read this manual, and the manual for your tractor, before assembly or operating, to acquaint yourself with the machines. It is the equipment owner's responsibility, if this machine is used by any person other than yourself, is loaned or rented, to make certain that the operator, prior to operating:

1. Reads and understands the operator's manuals.
2. Is instructed in safe and proper use.



Know your controls and how to stop tractor, engine, and implement quickly in an emergency. Read this manual and the one provided with your tractor.



Train all new personnel and review instructions frequently with existing workers. A person who has not read and understood all operating and safety instructions is not qualified to operate the machine. An untrained operator exposes himself and bystanders to possible serious injury or death.





Do not allow children to operate this machine.

SAFETY INSTRUCTIONS (continued)





OPERATIONAL SAFETY

-  The use of this equipment is subject to certain hazards which cannot be protected against by mechanical means or product design. All operators of this equipment must read and understand this entire manual, paying particular attention to safety and operating instructions, prior to using. If there is something in this manual you do not understand, ask your supervisor, or your dealer, to explain it to you.

-  Personal protection equipment including hard hat, safety glasses, safety shoes, and gloves are recommended during assembly, installation, operation, adjustment, maintaining, repairing, removal, or moving the implement. Do not allow long hair, loose fitting clothing or jewelry to be around moving parts.

-  Never permit any person other than the operator to ride or board the tractor or implement at any time. **ALLOW NO RIDERS!**

-  A heavy load can cause instability in driving a tractor. Make sure the front or rear of the tractor is properly counter-balanced with weights. Always drive slowly – especially around turns. An unstable tractor could steer badly and possibly tip over, causing injury or death.

-  Most accidents occur because of neglect or carelessness. Keep all helpers and bystanders at a safe distance. **REMEMBER FALLING BALES CAN ROLL OR TUMBLE.**

-  Always insert spears into the bale securely. Failure to insert spears into bale can allow bale to roll in an uncontrolled direction.

-  Do not handle bales that exceed the bale weight limitations of the implement.

-  Carry the bale slowly and as low as possible to the ground.

-  Operate the hydraulic controls smoothly, avoiding jerky operation.

-  Never use the tractor or implement to stop a rolling bale.















-  Only use a power unit equipped with a ROPS cab or rollover protective structure. Keep foldable ROPS systems in “locked up” position at all times. Keep seat belt fastened.

-  When stacking bales, **ALWAYS MAKE SURE BALES ARE PLACED SO THE STACK IS STABLE.**

SAFETY INSTRUCTIONS (continued)







OPERATIONAL SAFETY (continued)

-  Always load rear of tractor first and unload last when using a front loader.
-  Beware of lift clearance when raising loader or implement to maximum height.
-  Keep alert and watch the rear as well as the front when working with attached implements.
-  When maneuvering close to buildings or passing through narrow areas, be sure to allow sufficient clearance for the tractor, implement, and bale. Drive slowly.
-  Operate hydraulic controls from operator's seat only. Remain at controls until operating cycle is complete.
-  Stop loader gradually when lowering or lifting loads.
-  Allow for additional length of implement and bale on tractor while turning.
-  Never allow anyone to walk or work under a raised implement.
-  Be sure that people, livestock, or pets are not standing near the machine while operating.
-  Do not use implement for a work platform.
-  Do not lift or carry anyone on attachment.
-  ALWAYS lower implement to the ground or block securely before performing any maintenance work.
-  Stay alert for holes, rocks and roots in the terrain and other hidden hazards. Keep away from drop-offs.
-  Use extreme care and maintain minimum ground speed when transporting on hillside, over rough ground and when operating close to ditches or fences. Be careful when turning sharp corners.
-  Reduce speed on slopes and sharp turns to minimize tipping or loss of control. Be careful when changing directions on slopes. Do not start or stop suddenly on slopes. Avoid operation on steep slopes.

SAFETY INSTRUCTIONS (continued)













OPERATIONAL SAFETY (continued)

-  When using a unit, a minimum 20% of tractor and equipment weight must be on tractor front wheels. Without this weight, tractor could tip over, causing personal injury or death. The weight may be attained with a front end loader, front wheel weights, ballast in tires or front tractor weights. When attaining a minimum 20% of tractor and equipment weight on the front wheels, you must not exceed the ROPS weight certification. Weigh the tractor and equipment. Do not guess or estimate!
-  Avoid excessive speed during operation.
-  ALWAYS lower spear points to the ground when parking tractor. Raised spear points could cause injury to people or livestock.
-  Always shut off tractor and shift to "Park" or set brakes when leaving tractor. Always lower bucket or attachment to ground. Remove key when leaving tractor unattended.
-  Before operating equipment: if you have any questions regarding the proper assembly or operation, contact your dealer or representative.



TRANSPORT SAFETY

-  Comply with state and local laws governing highway safety and movement of farm machinery on public roads.
-  The use of flashing amber lights is acceptable in most localities. However, some localities prohibit their use. Local laws should be checked for all highway lighting and marking requirements.
-  When driving the tractor and equipment on the road or highway under 20 mph (32 kph) at night or during the day, use flashing amber warning lights and a slow moving vehicle (SMV) identification emblem.
-  Always be sure the implement is in the proper raised position for transport.
-  Reduce speed when transporting mounted implements to avoid bouncing and momentary loss of steering control.
-  Make sure large round bales transported on tractor rear 3 pt. hitch do not obstruct visibility of tractor's flashing lights or SMV sign.
-  When transporting large round bales, keep load as low as practical to maximize tractor stability.
-  Transporting large round bales on front loaders can limit visibility. Keep load low and go slow if visibility is obstructed. Always use extra care.
-  Turn curves or go up or down hills only at a low speed and at a gradual steering angle. Make certain that at least 20% of the tractor's weight is on the front wheels to maintain safe steering. Slow down on rough or uneven surfaces, and loose gravel.
-  Use extreme care and maintain minimum ground speed when transporting on hillside, over rough ground and when operating close to ditches or fences. Be careful when turning sharp corners.
-  Never allow riders on either tractor or implement. Falling off can kill.

SAFETY INSTRUCTIONS (continued)



MAINTENANCE SAFETY



Keep all persons away from operator control area while performing adjustments, service, or maintenance.



Make sure there is plenty of ventilation. Never operate the engine of the towing vehicle in a closed building. The exhaust fumes may cause asphyxiation.



Before working on this machine, drive to a level area, disengage the PTO, lower implement (or if working underneath, raise and block securely), shut off the engine, set the brakes, and remove the ignition keys.



Never work under equipment unless it is blocked securely. Never depend on hydraulic system to keep implement in raised position.



Always use personal protection devices such as eye, hand and hearing protectors, when performing any service or maintenance.



Periodically tighten all bolts, nuts and screws and check that all cotter pins are properly installed to ensure unit is in a safe condition.



When completing a maintenance or service function, make sure all safety shields and devices are installed before placing unit in service.



Never use your hands to locate a hydraulic leak on attachments. Use a small piece of cardboard or wood. Hydraulic fluid escaping under pressure can penetrate the skin.



Openings in the skin and minor cuts are susceptible to infection from hydraulic fluid. If injured by escaping hydraulic fluid, see a doctor at once. Gangrene and death can result. Without immediate medical treatment, serious infection and reactions can occur.



Check to ensure all safety signs are installed and in good condition. (See safety sign section for location drawing.)





Never replace hex bolts with less than grade five bolts unless otherwise specified, i.e. shear bolts. Refer to bolt torque chart for head identification marking.

SAFETY INSTRUCTIONS (continued)







MAINTENANCE SAFETY (continued)

-  Where replacement parts are necessary for periodic maintenance and servicing, genuine factory replacement parts must be used to restore your equipment to original specifications. The manufacturer will not claim responsibility for use of unapproved parts and/or accessories and other damages as a result of their use.
-  If equipment has been altered in any way from original design, the manufacturer does not accept any liability for injury or warranty.



STORAGE SAFETY

-  Following operation or when unhooking, stop the tractor, set the brakes, disengage the PTO, shut off the engine and remove the ignition keys.
-  Store the unit in an area away from human activity. Do not permit children to play on or around the stored unit.
-  Do not park equipment where it will be exposed to livestock for long periods of time. Damage and livestock injury could result.
-  Make sure all parked machines are on a hard, level surface and engage all safety devices.
-  If blocking is used, make sure it is solid and secure before leaving area.

**ALWAYS OBEY ALL SAFETY RULES!
ALWAYS BE CAREFUL!**

SAFETY SIGNS



WARNING

- Read and follow owner's manual before installing, operating, or performing maintenance on this loader. Observe safety recommendations in manual.
- Do not exceed weight limit of loader or tractor.
- Do not lift or carry anyone on loader or in bucket or attachment.
- For operator safety, always keep load in front of tractor hood. NEVER position load back over operator.
- Add recommended wheel ballast or rear weight for stability. When handling loads on both ends of tractor, load rear first and unload last.
- Set wheels wide for increased stability.
- Never raise loader to extreme heights on steep inclines.
- Do not stand or work under raised loader.
- Stop engine, lower arms, relieve all hydraulic pressure, and lock brakes before leaving operator's seat.
- When handling round bales with fork type equipment, be sure bolt-in stabilizer spike is installed. Without spike, uncontrolled bale movement could occur.
- Failure to observe the above precautions can result in serious injury or death.

101026

**NOTICE
1800 LB.
CAPACITY**

101112

**NOTICE
2000 LB.
CAPACITY**

101041

**NOTICE
2200 LB.
CAPACITY**

101113

**NOTICE
3000 LB.
CAPACITY**

101043

**REPLACE
SAFETY DECALS
IF DAMAGED
OR MISSING!**

INSTRUCTIONS

INTRODUCTION

Rear 3 pt. hitch mounted bale spears are designed, depending on model, to handle up to 3,000 lb. bales. All models feature a tapered “forged” spring steel spear designed for tight center bales allowing easier spear penetration into and withdrawal from bales. A special tapered socket provides support for the spear.

The 3 pt. spear models fit most Category I and II hitches. They do not connect to quick-hitches.

NOTE: The maximum load for the attachments is as follows:

<u>Model</u>	<u>Capacity</u>
BSF-1523	1,800 lbs.
BSF-122	2,200 lbs.
DBFS-30	3,000 lbs.
BSFA-20	2,000 lbs.

TRACTOR REQUIREMENTS AND PREPARATION

The required size of the tractor will be determined by the size and weight of the bales to be handled.

Remember, high moisture hay (silage) bales are very heavy in relation to similar size dry hay bales.

Always use a tractor large enough to safely handle your bales.

Check the tractor’s 3 point hydraulic lift system. It should operate up and down smoothly and hold its position when set. Refer to your tractor owner’s manual or dealer for any adjustments necessary to put the 3 point hydraulic lift system in good working order. (I&T shop manuals will list most specifications and adjustment instructions – available from most farm equipment dealers.)

Tractor should be equipped with stabilizer bars, adjustable sway chains, or sway blocks to keep the implement from swinging side to side.

Smaller size tractors may need front counter weights to counter-balance the weight of the implement.

It is recommended that the tractor be equipped with a Rollover Protection System (ROPS) and a seat belt that is used.

! CAUTION! !

Be sure your tractor is in good condition. Read all the safety precautions and make sure all tractor operators are familiar with the safety rules of operation.

! WARNING! !

When using the unit, a minimum 20% of tractor and equipment weight must be on tractor front wheels. Without this weight, tractor could tip up, causing possible loss of control and possible personal injury or death. The weight may be attained with a front end loader, front wheel weights, ballast in tires or front tractor weights. When attaining a minimum 20% of tractor and equipment weight on the front wheels, you must not exceed the ROPS weight certification. Weigh the tractor and equipment. **DO NOT GUESS OR ESTIMATE!**

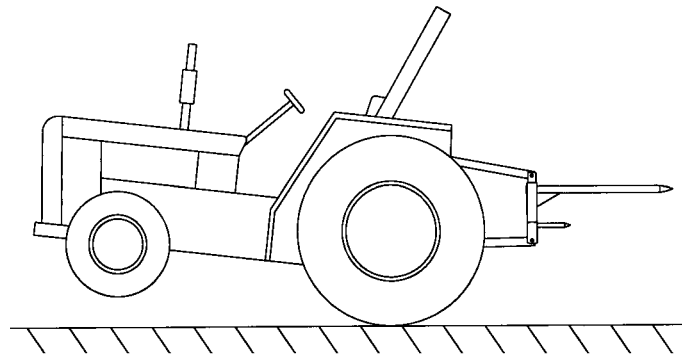

Figure 1. Tractor Stability

! WARNING! !

A heavy load can cause instability in driving a tractor. Make sure the front of the tractor is properly counter-balanced with weights. Always drive slowly – especially around turns. An unstable tractor could steer badly and possibly tip over, causing injury or death.

! WARNING! !

Power unit must be equipped with ROPS or ROPS cab and seat belt. Keep seat belt securely fastened. Falling off power unit can result in death from being run over or crushed. Keep foldable ROPS systems in “locked up” position at all times.

! WARNING! !

Do not exceed the maximum recommended large round bale weight listed for each of the loader spear models. Damage to the equipment or serious personal injury could result.

INSTRUCTIONS (continued)

ASSEMBLY

It is suggested that all the instructions be read before beginning assembly.

Check the exploded view of the 3 pt. bale spear model you have in this manual to get an idea of the relationship between the parts.

MODELS: BSF-1523, BSF-122, DBFS-30

Install the long forged main spear into the socket in the main frame. On the model BSF-122, install the shorter spear in the lower socket.

The threads and nut are metric – be sure correct tools are used.

Locate the lift pins for your hitch and tighten securely.

MODELS: BSFA-20

Locate the lift pins and install the frame on the 3 pt. hitch of the tractor.

On the BSFA-20, place the main spear mount so that the flat mounting plate is against the center of the main frame tube assembly.

Locate the two (2) $\frac{5}{8}$ " x 3" x $4\frac{1}{2}$ " U-Bolts around the vertical tube and through the holes in the main spear mounting plate. Install the lockwashers and nuts on the threaded ends of the two (2) U-Bolts.

Install the long forged main spear into the socket on the mounting plate. Secure with the $\frac{7}{16}$ " x 3" long bolt.

It is suggested that you locate the main spear about in the middle of the vertical 3" square tube and then adjust it after trying it with your bales.

OPERATION

The operator is responsible for the safe operation of this equipment. The operator must be properly trained. Operators should be familiar with the tractor and attachment, and all safety practices before starting operation. Read the safety rules and safety signs on pages 1-9.

Be sure tractor is properly counterbalanced with weights before attempting to lift any load with the Bale Spear Attachment.

If you are handling bales with both the front end loader and the 3 pt. hitch on the tractor, always load the 3 pt. attachment first and unload last.

With the tractor, push the spear into the large hay bale. Make sure you have penetrated the hay bale far enough so the bale doesn't want to come off the end of the spear. If, when you initially pick the bale up, it tends to droop rearward, this would indicate you have not penetrated the bale far enough.

NOTE: Soft center bales will tend to droop after being lifted by a single spear. Placing the spear in a lower position will allow for more lifting height and lessen the load on the stabilizer spears.

NOTE: Always make sure bale spear fully penetrates the bale. Partial penetration locates all the weight of the bale on the outer end and can damage spear. Not covered under warranty.

NOTE: In cold weather, a bale frozen to the ground may exceed the lifting capacity of spear. Damage to spear may occur. Not covered under warranty.

The model DBFS-30 has two forged spears. This allows the handling of round bales without the bale turning. Bales can be handled in the same position each time. The model DBFS-30 can also handle heavier bales.

HANDLE ROUND BALES SAFELY:

Improper use of loaders to handle round bales can result in serious injury or death to the tractor/loader operator. This could be caused by the bale rolling back down the loader into the operator's station.

For optimum stability and visibility:

- Do not handle bales that exceed the bale weight limitations of the bale spear.
- Never use the tractor to stop a rolling bale.
- Allow for additional length of bale on tractor while turning.
- Use particular care when working on inclines and hill-sides.

MAINTENANCE

Periodically check all bolts to make sure they are tight.

Check the large nut on the forged spears to make sure it is tight.

Replace safety signs and instruction decals if damaged or missing.

BSF-1523 PARTS LIST

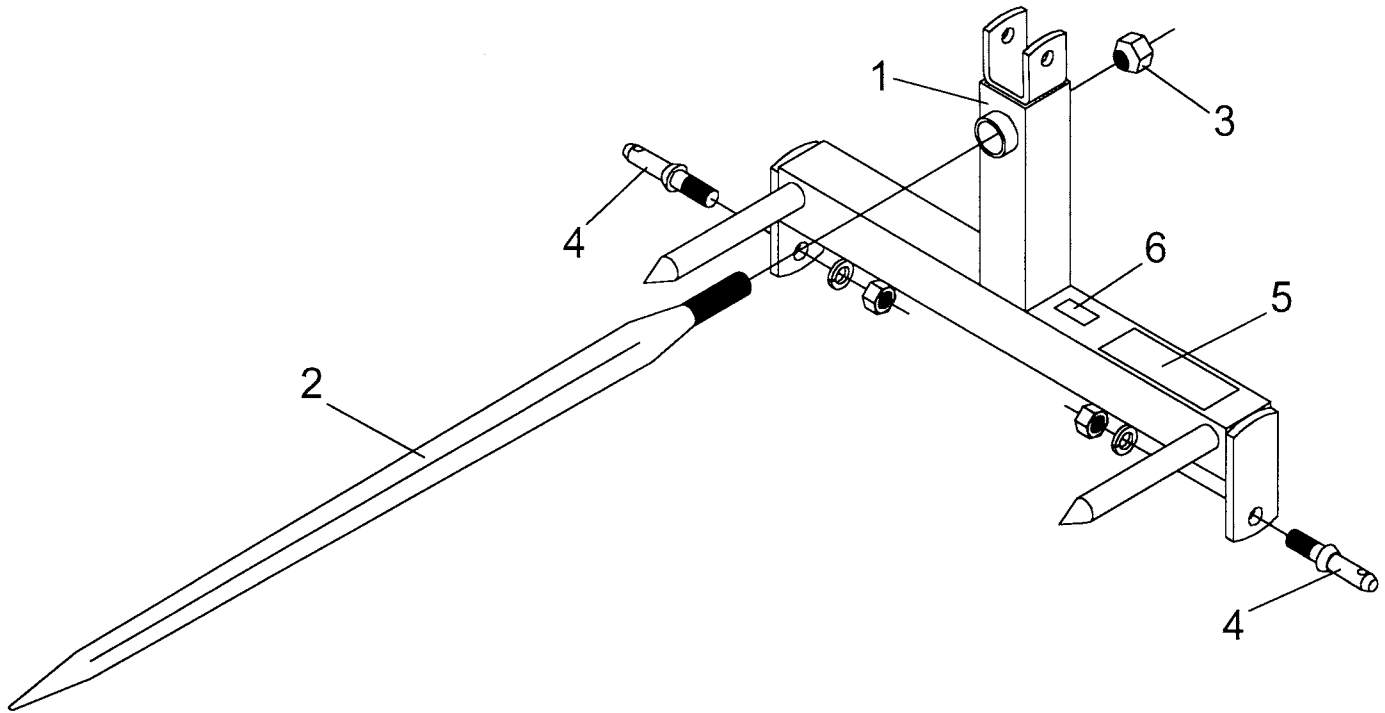

Ref. No.	Part No.	Description	No. Req'd.
1	830236	Main Frame Weldment	1
2	831290	Tine, Hay	1
3	831291	Nut, Tine	1
4	590108	Pin, Lift (AK-578)	2
5	101026	Safety Sign-Caution (Hay Equipment)	1
6	101112	Safety Sign-Notice (1800 Lb. Capacity)	1

BSF-122 PARTS LIST

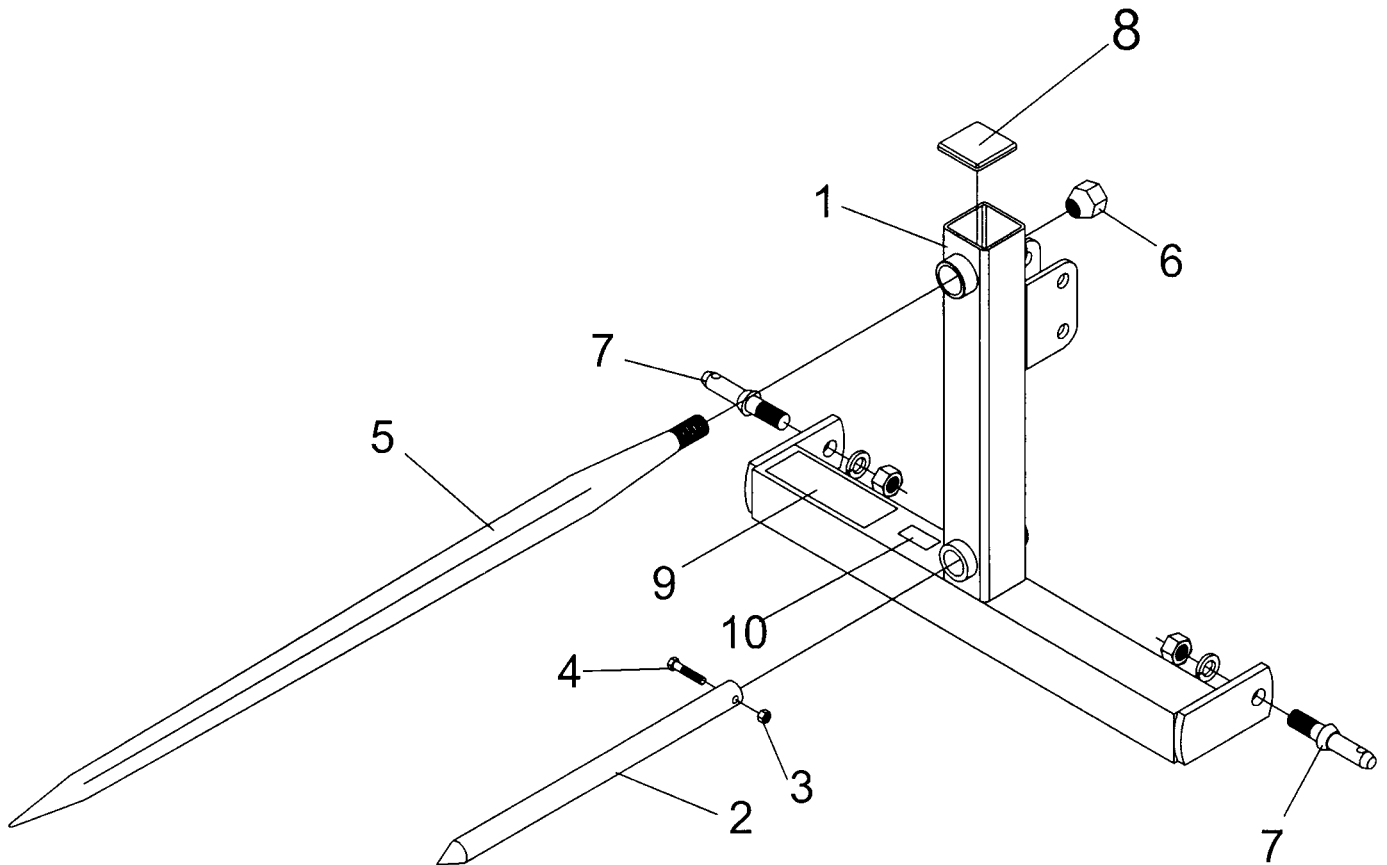

Ref. No.	Part No.	Description	No. Req'd.
1	830383	Main Frame Weldment	1
2	830938	Spear, 1 1/4" Dia. x 21" Long	1
3	2500055	Nut, Hex 3/8"-16NC Stamplock	1
4	2503039	Bolt, 3/8"-16NC x 2 1/2" Hex Head Gr.2	1
5	831273	Tine, Hay 49.2"	1
6	831274	Nut, Tine	1
7	590108	Pin, Lift (AK-578)	2
8	2504308	Cap, Plastic (80MM) Pur.	1
9	101026	Safety Sign-Caution (Instructions)	1
10	101113	Safety Sign-Notice (2200 Lb. Capacity)	1

DBFS-30 PARTS LIST

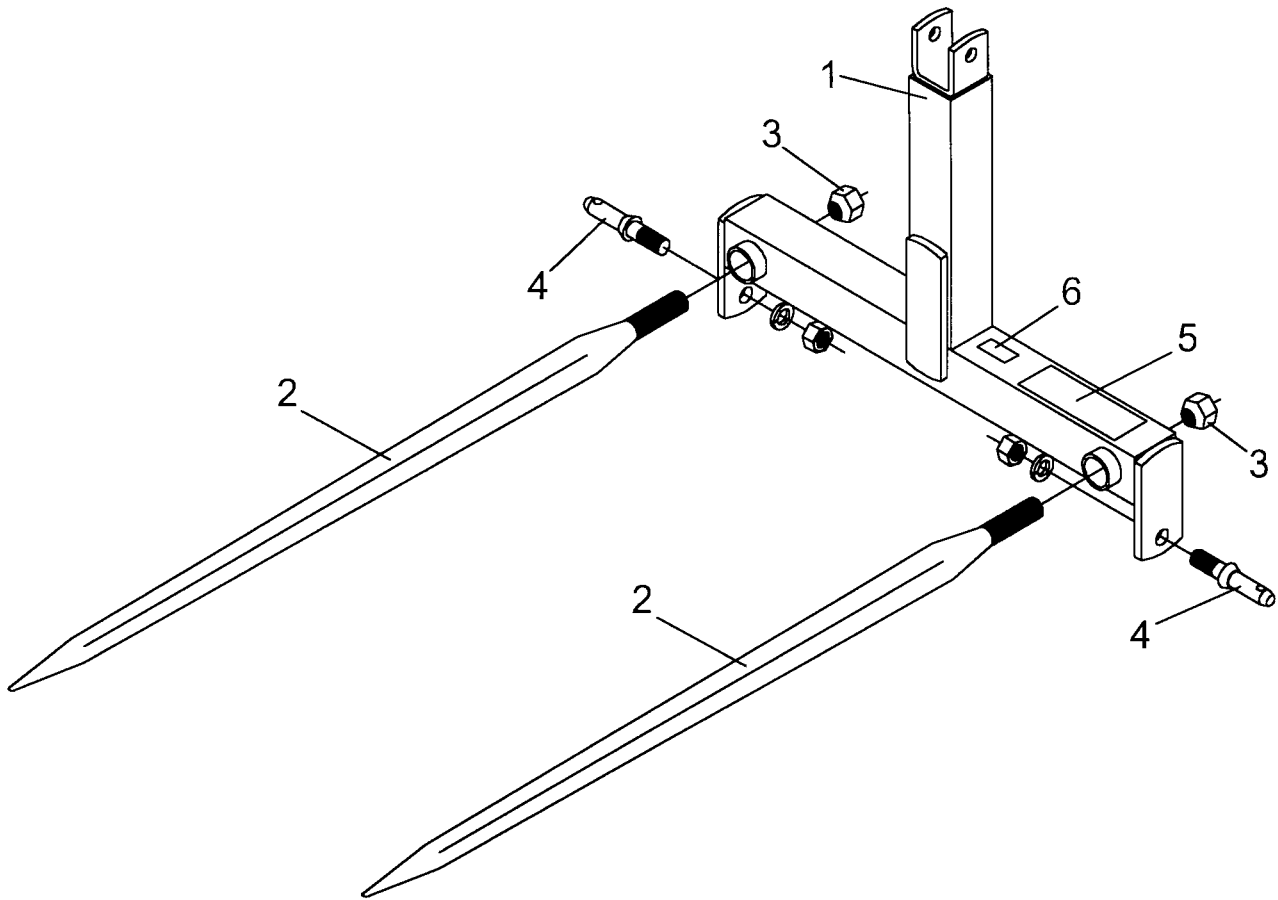

Ref. No.	Part No.	Description	No. Req'd.
1	830771	Main Frame Weldment	1
2	831290	Tine, Hay	2
3	831291	Nut, Tine	2
4	590108	Pin, Lift (AK-578)	2
5	101026	Safety Sign-Caution (Hay Equipment)	1
6	101043	Safety Sign-Notice (3000 Lb. Capacity)	1

BSFA-20 PARTS LIST

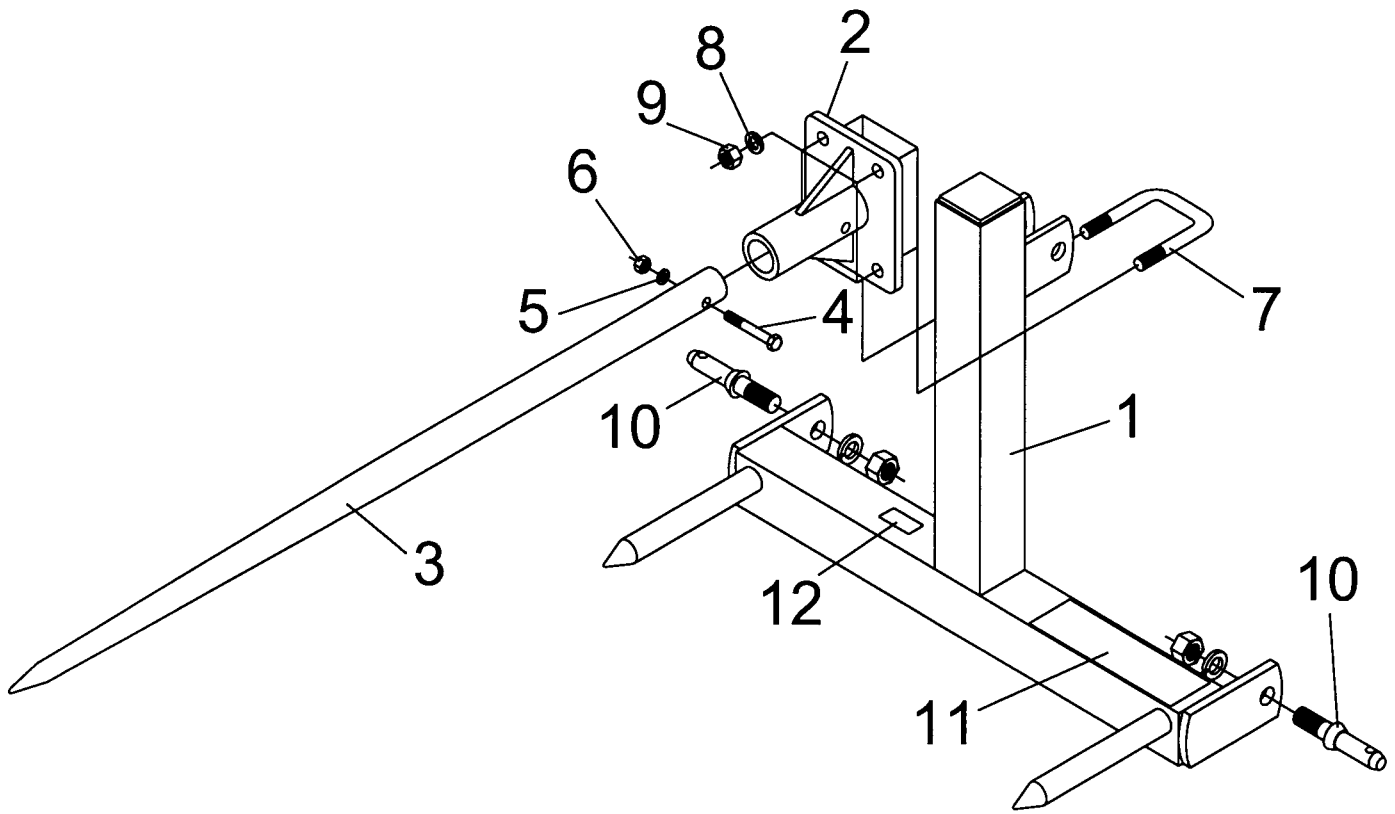

Ref. No.	Part No.	Description	No. Req'd.
1	830921	Main Frame Weldment	1
	830925	Spear & Socket Assembly (includes #2 thru #9)	1
2	830926	Socket Weldment	1
3	830928	Forged Spear	1
4	2503054	Bolt 7/16"-14NC x 3" Hex Head Grade 5	1
5	2502006	Washer 7/16" Springlock	1
6	2500012	Nut 7/16"-14NC Full Hex	1
7	830214	U-Bolt 5/8"-11NC 3" x 4 1/2"	2
8	2502007	Washer 5/8" Springlock	4
9	2500013	Nut 5/8"-11NC Full Hex	4
10	590108	Lift Pin (AK-578)	2
11	101026	Safety Sign - Caution (Instructions)	1
12	101041	Safety Sign - Notice (2000 Lbs.)	1

⚠ SAFETY PRECAUTIONS ⚠

**MOST ACCIDENTS OCCUR BECAUSE OF NEGLIGENCE OR CARELESSNESS.
AVOID NEEDLESS ACCIDENTS BY FOLLOWING ALL OF THE SAFETY PRECAUTIONS LISTED BELOW.**

- Machinery should be operated only by those who are responsible and are authorized to do so.
- Stop the engine, lower all equipment, lock the brakes, and remove the ignition key before dismounting from the tractor.
- Never stand between tractor and implement while tractor is being backed to hitch.
- Loose fitting clothing should not be worn, to avoid catching on various parts.
- Detach implement in area where children normally do not play.
- When performing adjustments or maintenance on an implement, first lower it to the ground or block it securely at a workable height.
- Only a qualified operator should be permitted on tractor when in operation; no riders allowed.
- Make certain everyone is in the clear before starting tractor or raising or lowering equipment.
- Operate the tractor and implement only while seated in the driver's seat.
- Reduce speed when transporting mounted implements to avoid bouncing and momentary loss of steering control.
- A heavy load can cause instability of the tractor. Use extreme care during road travel. Slow down on turns and watch out for bumps. Tractor may need front counterweights to counter-balance the weight of the implement.
- Reduce speed on hillsides or curves so there is no danger of tipping.
- Avoid driving too close to the edge of ditches or creeks.
- Do not transport implement on public roads without reflectors and slow moving vehicle emblem in daylight and with approved warning lights at night and other periods of poor visibility.
- Due to the width of some implements, use extra caution on highways, farm roads, and when approaching gates.
- Always be sure the implement is in the proper position for transport.
- Keep alert and watch the front as well as the rear when working with the implement.

OWNER'S/ OPERATOR'S MANUAL

MODEL NO.'s
BSF-1523
BSF-122
DBFS-30
BSFA-20

**WHEN ORDERING REPAIR
PARTS, ALWAYS GIVE THE
FOLLOWING INFORMATION:**

1. PART NUMBER
2. PART DESCRIPTION
3. MODEL NUMBER
4. NAME OF ITEM

DECEMBER 2005

STATEMENT OF POLICY

It is the policy of Worksaver, Inc. to improve its products where it is possible and practical to do so. Worksaver, Inc. reserves the right to make changes or improvements in design and construction at any time, without incurring the obligation to make these changes on previously manufactured units.

3 PT. HITCH BALE SPEARS

LIMITED WARRANTY

Worksaver, Inc. warrants its implements, parts and accessories to be free from defects in materials and workmanship for a period of six (6) months from date of purchase. Upon written approval, Worksaver, Inc. will repair or exchange without charge any part, which upon examination by Worksaver, Inc. or its authorized agent, shall disclose to be defective.

This does not apply to (1) parts that have worn out in normal use, (2) parts broken because of improper assembly or operation by the customer, (3) parts accidentally damaged, (4) failure of parts traceable to improper care, (5) parts failing through use of implement for purposes other than those for which it was designed.

The obligations assumed by Worksaver, Inc. and the limitations expressed herein are in lieu of all other warranties expressed or implied.

WORKSAVER, INC.

P.O. BOX 100 LITCHFIELD, IL 62056-0100 (217) 324-5973
WEB: <http://www.worksaver.com> E-MAIL: sales@worksaver.com