

OWNER'S/ OPERATOR'S MANUAL

MODEL NO.'s

ETG-5

ETG-6

ETG-5JD

ETG-6JD

ETG-26

CAUTION

For Safe Operation
Read Rules And
Instructions Carefully

SI NO LEEINGLES, PIDA AYUDA
A AIGUIEN QUE SI LO LEA
PARA QUE LE TRADUZCA LAS
MEDIDAS DE SEGURIDAD.

ETG-5

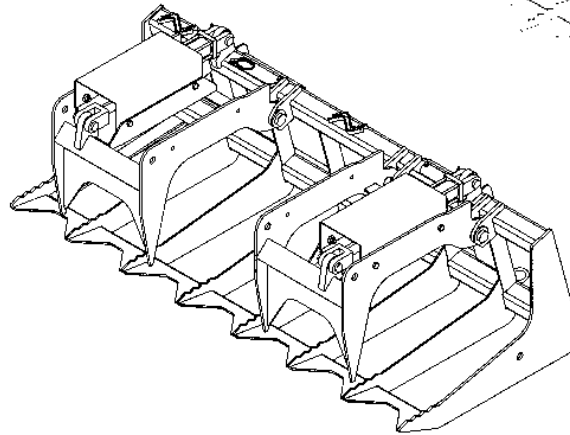

ETG-26

TINE GRAPPLE BUCKETS for Skid Steer and Tractor Front Loaders

**Safety Instructions
Tractor Preparation
Operating Instructions**

**Assembly & Mounting
Maintenance
Repair Parts**

CAUTION

**THE FOLLOWING SAFETY PRECAUTIONS SHOULD BE THOROUGHLY UNDERSTOOD
BEFORE ATTEMPTING TO BEGIN ASSEMBLING THIS MACHINE**

1. Select an area for assembly that is clean and free of any debris which might cause persons working on the assembly to trip.
2. Do not lift heavy parts or assemblies. Use crane, jack, tackle, fork trucks or other mechanical devices.
3. Preview the assembly instructions in your operator's manual before proceeding further.
4. If the assembly instructions call for parts or assemblies to be blocked up, use only blocking material that is in good condition and is capable of handling the weight of the assembly to be blocked. Also insure that the blocking material is on a clean, dry surface.
5. Never put hands, or any part of body, under blocked up assemblies if at all possible.
6. After completing assembly, thoroughly inspect the machine to be sure that all nuts, bolts, hydraulic fittings or any other fastened assemblies have been thoroughly tightened.
7. Before operating the machine, thoroughly read the operation section of your operator's manual.
8. Before operating, read the maintenance section of your operator's manual to be sure that any parts requiring lubrication, such as gearboxes, are full, to avoid any possible damage.
9. **Before operating equipment – If you have any questions regarding the proper assembly or operation, contact your dealer or representative.**

TABLE OF CONTENTS

WARRANTY	2
SAFETY INFORMATION	3 - 8
SAFETY SIGNS	9 - 10
PREPARATION INSTRUCTIONS	11 - 15
OPERATING INSTRUCTIONS	16 - 17
SERVICE & MAINTENANCE	18 - 19
PARTS LISTS	20 - 25
TROUBLE-SHOOTING	26 - 27

SI NO LEEINGLES, PIDA AYUDA A AIGUIEN QUE SI LO LEA PARA QUE LE TRADUZCA LAS MEDIDAS DE SEGURIDAD.

STATEMENT OF POLICY

It is the policy of Worksaver, Inc. to improve its products where it is possible and practical to do so. Worksaver, Inc. reserves the right to make changes or improvements in design and construction at any time, without incurring the obligation to make these changes on previously manufactured units.

TO THE OWNER:

Read this manual before using your Tine Grapple Attachment. This manual is provided to give you the necessary operating and maintenance instructions for keeping your Tine or Scrap Grapple Attachment in top operating condition. Please read this manual thoroughly. Understand what each control is for and how to use it. Observe all safety signs on the machine and noted throughout the manual for safe operation of implement. Keep this manual handy for ready reference.

Like all mechanical products, it will require cleaning and upkeep. Lubricate the Tine Grapple Attachment as specified.

Use only genuine Worksaver, Inc. service parts. Substitute parts will void the warranty and may not meet standards required for safe and satisfactory operation. Record the model and serial number of your Tine Grapple Attachment here:

Model: _____ Serial Number: _____

Date Purchased: _____

RETAIL CUSTOMER'S RESPONSIBILITY

It is the Retail Customer and/or Operator's responsibility to read the Operator's Manual, to operate, lubricate, maintain, and store the product in accordance with all instructions and safety procedures. Failure of the operator to read the Operator's Manual is a misuse of this equipment.

It is the Retail Customer and/or Operator's responsibility to inspect the product and to have any part(s) repaired or replaced when continued operation would cause damage or excessive wear to other parts or cause a safety hazard.

It is the Retail Customer's responsibility to deliver the product to the authorized Worksaver Dealer, from whom he purchased it, for service or replacement of defective parts which are covered by warranty. Repairs to be submitted for warranty consideration must be made within forty-five (45) days of failure.

It is the Retail Customer's responsibility for any cost incurred by the Dealer for traveling to or hauling of the product for the purpose of performing a warranty obligation or inspection.

LIMITED WARRANTY

Worksaver warrants to the original purchaser of any new Tine Grapple Attachment, that the equipment be free from defects in material and workmanship for a period of TWELVE (12) MONTHS COMMENCING ON THE DATE OF DELIVERY OF THE PRODUCT TO THE ORIGINAL PURCHASER. This warranty will apply if notified to Worksaver, Inc. within thirty (30) days after such defect is discovered.

The warranty registration must be completed and returned to Worksaver, Inc.

Replacement or repair parts installed in the equipment covered by this warranty are warranted for ninety (90) days from the date of purchase of such part or to the expiration of the applicable new equipment warranty period, whichever occurs later.

Such parts shall be provided at no cost to the user during regular working hours. Worksaver reserves the right to inspect any equipment or parts which are claimed to have been defective in material or workmanship.

This warranty is extended solely to the original purchaser of the product. Should the original purchaser sell or otherwise transfer this product to a third party, this warranty does not transfer to the third party purchaser in any way. There are no third party beneficiaries of this warranty.

DISCLAIMER OF IMPLIED WARRANTIES & CONSEQUENTIAL DAMAGES

Worksaver shall not be liable for any incident or consequential losses, damages or expenses, arising directly or indirectly from the product, whether such claim is based upon breach of contract, breach of warranty, negligence, strict liability in tort or any other legal theory.

Worksaver's obligation under this warranty, to the extent allowed by law, is in lieu of all warranties, implied or expressed, including implied warranties of merchantability and fitness for a particular purpose and any liability for incidental and consequential damages with respect to the sale or use of the items warranted. Such incidental and consequential damages shall include but not be limited to: transportation charges other than normal freight charges; cost of installation other than cost approved by Worksaver; duty; taxes; charges for normal service or adjustments; loss of crops or any other loss of income; rental of substitute equipment, expenses due to loss, damage, detention or delay in the delivery of equipment or parts resulting from acts beyond the control of Worksaver.

THIS WARRANTY SHALL NOT APPLY:

1. To vendor items which carry their own warranties, such as hydraulic cylinders, hydraulic hoses, and fittings.
2. If the unit has been subjected to misapplication, abuse, misuse, negligence, fire or other accident.
3. If parts not made or supplied by Worksaver have been used in connection with the unit, if, in sole judgement of Worksaver such use affects its performance, stability, or reliability.
4. If the unit has been altered or repaired outside of an authorized Worksaver dealership in a manner which, in the sole judgement of Worksaver affects its performance, stability or reliability.
5. To normal maintenance service and normal replacement items such as gearbox lubricant, hydraulic fluid, worn blades, or to normal deterioration of such things as hoses and exterior finish, due to use or exposure.
6. To expendable or wear items such as cutting edge, plow bolts, tine points and other items that in the company's sole judgement is a wear item.

NO EMPLOYEE OR REPRESENTATIVE OF WORKSAVER IS AUTHORIZED TO CHANGE THIS WARRANTY IN ANY WAY OR GRANT ANY OTHER WARRANTY UNLESS SUCH CHANGE IS MADE IN WRITING AND SIGNED BY WORKSAVER'S SERVICE MANAGER, POST OFFICE BOX 100, LITCHFIELD, ILLINOIS 62056-0100.

This warranty is subject to the warranty registration being submitted within sixty (60) days after purchase. For warranty services, contact your selling dealer.

To the Owner/Operator/Dealer

All implements with moving parts are potentially hazardous. There is no substitute for a cautious, safe-minded operator who recognizes the potential hazards and follows reasonable safety practices. The manufacturer has designed this attachment to be used with all its safety equipment properly attached to minimize the chance of accidents.

BEFORE YOU START!!

**Read the safety messages on the implement and shown in your manual.
Observe the rules of safety and common sense!**



THIS SYMBOL MEANS

- ATTENTION!
- BECOME ALERT!
- YOUR SAFETY IS INVOLVED!

THIS SAFETY ALERT SYMBOL IDENTIFIES IMPORTANT SAFETY WARNING MESSAGES. CAREFULLY READ EACH WARNING MESSAGE THAT FOLLOWS. FAILURE TO UNDERSTAND AND OBEY A SAFETY WARNING, OR RECOGNIZE A SAFETY HAZARD, COULD RESULT IN AN INJURY OR DEATH TO YOU OR OTHERS AROUND YOU. THE OPERATOR IS ULTIMATELY RESPONSIBLE FOR THE SAFETY OF HIMSELF, AS WELL AS OTHERS, IN THE OPERATING AREA OF THE PRIME MOVER AND ATTACHED EQUIPMENT.

UNDERSTAND SIGNAL WORDS

Note the use of the signal words **DANGER**, **WARNING** and **CAUTION** with the safety messages. The appropriate signal word for each has been selected using the following guidelines:

DANGER: Indicates an imminently hazardous situation that, if not avoided, will result in death or serious injury. This signal word is to be limited to the most extreme situations typically for machine components which, for functional purposes, cannot be guarded.

WARNING: Indicates a potentially hazardous situation that, if not avoided, could result in death or serious injury, and includes hazards that are exposed when guards are removed. It may also be used to alert against unsafe practices.

CAUTION: Indicates a potentially hazardous situation that, if not avoided, may result in minor or moderate injury. It may also be used to alert against unsafe practices.

If you have questions not answered in this manual or require additional copies or the manual is damaged, please contact your dealer or the manufacturer directly.

GENERAL INFORMATION

The purpose of this manual is to assist in assembling, mounting, operating, and maintaining your attachment. Read this manual carefully to obtain information and instructions that will help you realize years of safe and dependable service.

The illustrations and data used in this manual were current at the time of printing, but due to possible engineering and/or production changes, this product may vary slightly in detail. Worksaver, Inc. reserves the right to redesign and/or change components as may be necessary without notification to anyone.

Throughout this manual, references may be made to:

Prime Mover	The engine-driven machine to which this product must be attached.
Right, Left, Front, Rear	Directions that are determined in relation to the operator of the equipment when seated in the normal operation position.

IMPORTANT SAFETY INFORMATION!

WARNING!



READ MANUAL PRIOR TO INSTALLATION

Improper installation, operation, or maintenance of this equipment could result in serious injury or death. Operators and maintenance personnel should read this manual, as well as all manuals related to this equipment and the prime mover thoroughly before beginning installation, operation, or maintenance. **FOLLOW ALL SAFETY INSTRUCTIONS IN THIS MANUAL AND THE PRIME MOVER'S MANUAL(S).**



READ AND UNDERSTAND ALL SAFETY STATEMENTS

Read all safety decals and safety statements in all manuals prior to operating or working on this equipment. Know and obey all OSHA regulations, local laws, and other professional guidelines for your operation. Know and follow good work practices when assembling, maintaining, repairing, mounting, removing, or operating this equipment.



KNOW YOUR EQUIPMENT

Know your equipment's capabilities, dimensions, and operations before operating. Visually inspect your equipment before you start, and never operate equipment that is not in proper working order with all safety devices intact. Check all hardware to ensure it is tight. Make certain that all locking pins, latches, and connection devices are properly installed and secured. Remove and replace any damaged, fatigued, or excessively worn parts. Make certain all safety decals are in place and are legible. Keep decals clean, and replace them if they become worn or hard to read.

WARNING!



PROTECT AGAINST FLYING DEBRIS

Always wear proper safety glasses, goggles, or a face shield when driving pins in or out, or when any operation causes dust, flying debris, or any other hazardous material.

WARNING!



LOWER OR SUPPORT RAISED EQUIPMENT

Do not work under raised booms without supporting them. Do not use support material made of concrete blocks, logs, buckets, barrels, or any other material that could suddenly collapse or shift positions. Make sure support material is solid, not decayed, warped, twisted, or tapered. Lower booms to ground level or on blocks. Lower booms and attachments to the ground before leaving the cab or operator's station.

WARNING!



DO NOT MODIFY MACHINE OR ATTACHMENTS

Modifications may weaken the integrity of the attachment and may impair the function, safety, life, and performance of the attachment. When making repairs, use only the manufacturer's genuine parts, following authorized instructions. Other parts may be substandard in fit and quality. Never modify any ROPS (Roll Over Protection Structure) or FOPS (Falling Object Protective Structure) equipment or device. Any modification must be authorized in writing by the manufacturer.

SAFETY INSTRUCTIONS (continued)

WARNING!



USE CARE WITH HYDRAULIC FLUID PRESSURE

Hydraulic fluid under pressure can penetrate the skin and cause serious injury or death. Hydraulic leaks under pressure may not be visible. Before connecting or disconnecting hydraulic hoses, read your prime mover's operator's manual for detailed instructions on connecting and disconnecting hydraulic hoses or fittings.

- Keep unprotected body parts, such as face, eyes, and arms as far away as possible from a suspected leak. Flesh injected with hydraulic fluid may develop gangrene or other permanent disabilities.
- Openings in the skin and minor cuts are susceptible to infection from hydraulic fluid.
- If injured by injected fluid, see a doctor at once. If your doctor is not familiar with this type of injury, ask him to research it immediately to determine proper treatment. Without immediate medical treatment, serious infection and reactions can occur.
- Wear safety glasses, protective clothing, and use a piece of cardboard or wood when searching for hydraulic leaks. **DO NOT USE YOUR HANDS!**

SEE ILLUSTRATION:

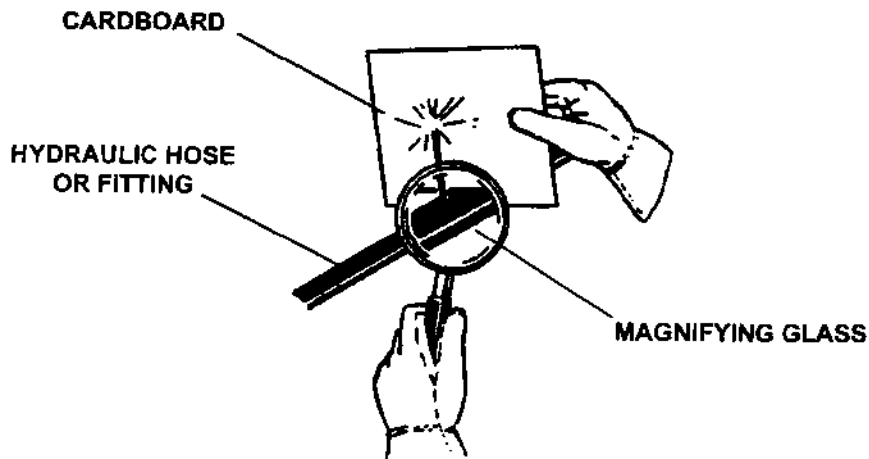

WARNING!



SAFELY MAINTAIN AND REPAIR EQUIPMENT

- Do not wear loose clothing or any accessories that can catch in moving parts. If you have long hair, cover or secure it so that it does not become entangled in the equipment.
- Work on a level surface in a well-lit area.
- Use properly grounded electrical outlets and tools.
- Use the correct tools for the job at hand. Make sure they are in good condition for the task required.
- Wear the protective equipment specified by the tool manufacturer.

SAFETY INSTRUCTIONS (continued)

WARNING!



SAFELY OPERATE EQUIPMENT

Do not operate equipment until you are completely trained by a qualified operator in how to use the controls, know its capabilities, dimensions, and all safety requirements. See your machine's manual for these instructions.

- Do not operate the equipment from anywhere other than the correct operator's position.
- Only use a power unit equipped with a ROPS cab or rollover protective structure. Keep foldable ROPS systems in "locked up" position at all times. Keep seat belt fastened.
- Never place any part of your body where it would be in danger if movement should occur during assembly, installation, operation, maintaining, repairing, removal, or moving the implement.
- The use of any loader attachment is NOT recommended on tractor with a tricycle wheel arrangement. Tricycle type tractors are unstable for front loader use.
- A heavy load can cause instability in driving a power unit. Make sure the front or rear of the power unit is properly counter-balanced with weights. Always drive slowly – especially around turns. An unstable power unit could steer badly and possibly tip over, causing injury or death.
- When using a tractor equipped with a front loader, set the wheels wide for increased stability.
- Do not allow others to ride on the power unit with an operator. Riders are subject to injury such as being struck by foreign objects or being thrown off. Riders obstruct the operator's view resulting in unsafe operation. **Never allow anyone to ride on the implement!**
- Always check locking pins before tilting or operating any attachment.
- Keep all step plates, grab bars, pedals, and controls free of dirt, grease, debris, and oil.
- Never allow anyone to be around the equipment when it is operating.
- Specified lift capacities must not be exceeded. See loader specifications.
- An operator must not use drugs or alcohol, which can change their alertness or coordination. An operator taking prescription or over-the-counter drugs should seek medical advice on whether or not they can safely operate equipment.
- Never use any of these attachments for a work platform or personnel carrier.
- Operate the loader controls smoothly, avoiding jerky operation. Stop loader gradually when lowering or lifting loads.
- Beware of low electrical wires when loader is raised. Serious injury or death can result if contact is made.
- When handling material on a slope, always approach the material with the power unit facing uphill.

SAFETY INSTRUCTIONS (continued)

WARNING!



OPERATIONAL SAFETY (continued)

- When maneuvering close to buildings or passing through narrow areas, be sure to allow sufficient clearance for the power unit, loader, and load. Drive slowly.
- Make sure all loads are secure before lifting. If lifting with the grapple and the load appears to be unstable, lower the load, open the grapple and reposition the load to attain full stability.
- Do not heap load heavy material where the combined weight of the bucket and the material could exceed the rated lifting capacity of the loader.
- Be sure the load does not stick out too far in front of the bucket. A light load sticking out too far can have the same tipping effect as a heavy load carried in close.
- Keep load centered on grapple bucket and loader. Unbalanced loads increase possibility of tipping or roll-over.
- When handling brush or branches, be aware of branches that might contact power unit or operator.
- When cleaning up old building sites, check for live utility lines. Always be sure electric, gas, and water lines have been properly disconnected.
- Check material to be handled, especially at old building sites or dumps. Be alert for any hazardous material that could be released by grapple bucket contact. If in doubt, check with professional waste haulers.
- When stacking logs or stumps, **ALWAYS MAKE SURE MATERIAL IS PLACED SO THE STACK IS STABLE.**
- Do not handle loads that exceed the weight limitations of the loader.
- Carry the loads slowly and as low as possible to the ground. Avoid excessive speed during operation.
- Never leave equipment unattended with the prime mover's engine running, or with this attachment in a raised position.
- Do not handle round bales unless loader is equipped with approved bale handling attachments.
- Do not detach loader from tractor with any of these attachments installed. Equip loader with material bucket when detaching.
- Before exiting the prime mover, lower the attachment to the ground, apply the brakes, turn off the prime mover's engine, and remove the key.
- Do not alter or remove any safety feature from the prime mover or this attachment.
- Know your work site safety rules as well as traffic rules and flow. When in doubt on any safety issue, contact your supervisor or safety coordinator for an explanation.

SAFETY INSTRUCTIONS (continued)

WARNING!



KNOW WHERE UTILITIES ARE

Observe overhead electrical and other utility lines. Be sure equipment will clear them. When digging, call your local utilities for location of buried utility lines, gas, water, and sewer, as well as any other hazard you may encounter. **Beware of low electrical wires when loader is raised. Serious injury or death can result if contact is made.**



TRANSPORTING ALL ATTACHMENTS

- Travel only with the attachment as close to the ground as possible. Drive slowly over rough ground and on slopes.
- When driving on public roads use safety lights, reflectors, Slow Moving Vehicle signs etc., to prevent accidents. Check local government regulations that may affect you.
- Do not drive close to ditches, excavations, etc., cave in could result.
- When on a slope, keep the load low and proceed with extreme caution. Do not drive ACROSS a steep slope - drive straight up and down.
 - With a LOADED attachment - face the attachment and load uphill.
 - With an EMPTY attachment - face the attachment downhill.
- Avoid sudden starts and stops while traveling up or downhill. Avoid parking on a slope. Slow down on sharp turns and slopes to prevent tipping and/or loss of control. Avoid slopes when surface is wet, slippery grass or soil. Be careful when changing directions on slopes.
- Use extra care when loading or unloading unit onto trailer or truck. NEVER secure rods or linkages on unit that could be damaged when transporting.
- Do not smoke when refueling. Allow room in the gas tank for expansion. Wipe up any spilled fuel. Secure cap tightly when done.



MAINTAINING ALL ATTACHMENTS

- Before working on this machine, drive to a level area, relieve hydraulic pressure, lower implement (or if working underneath, raise and block securely), shut off the engine, set the brakes, and remove the ignition keys. Relieve hydraulic pressure prior to doing any maintenance.
- Never work under equipment unless it is blocked securely. Never depend on hydraulic system to keep implement in raised position.
- Keep all persons away from operator control area while performing adjustments, service, or maintenance.
- Worn, damaged, or illegible safety decals must be replaced. New safety decals can be ordered from your dealer or from the manufacturer.



STORAGE SAFETY

- Store the unit in an area away from human activity. Do not permit children to play on or around the stored unit.
- Make sure all parked machines are on a hard, level surface and engage all safety devices. Storage location should be level and solid to make connecting and unconnecting to prime mover easy.
- If blocking is used, make sure it is solid and secure before leaving area.

SAFETY SIGNS

⚠ WARNING

TO AVOID SERIOUS INJURY OR DEATH:

- Read Operator's Manual before operating, servicing or repairing equipment. Follow all safety rules and instructions. (Manuals are available from your selling dealer.)
- Never allow riders
- Keep bystanders away from equipment during operation.
- Operate from operator's seat only.
- Keep all shields in place and in good condition.
- Lower equipment to ground, stop engine, remove key and set brake before dismounting power unit.
- Never allow children or untrained persons to operate equipment

FAILURE TO FOLLOW THESE INSTRUCTIONS CAN RESULT IN INJURY OR DEATH.

101288

⚠ WARNING



CRUSHING AND PINCHING HAZARD

- Be extremely careful with various parts of the machine. Moving parts can crush or pinch body parts.
- Operate controls from operator's seat only.
- Make sure parking brake is engaged before leaving operator's seat.
- Stand clear of machine while in operation or when it is being raised or lowered.

FAILURE TO FOLLOW THESE INSTRUCTIONS COULD RESULT IN SERIOUS INJURY OR DEATH.

101288

⚠ WARNING



To avoid injury or death caused by falling attachment:



- Quick lock pins must be installed at all times.

101296

(For models ETG-5JD & ETG-6JD only.)

⚠ WARNING



HIGH-PRESSURE FLUID HAZARD

To prevent serious injury or death:

- Relieve pressure on system before repairing or adjusting or disconnecting.
- Wear proper hand and eye protection when searching for leaks. Use wood or cardboard instead of hands.
- Keep all components in good repair.

101122

BE CAREFUL!

Use a clean, damp cloth to clean safety decals. Avoid spraying to close to decals when using a pressure washer; high-pressure water can enter through very small scratches or under edges of decals causing them to peel or come off.

⚠ WARNING



**Crush hazard.
Keep clear.**

101295

REMEMBER: If Safety Signs have been damaged, removed, become illegible or parts replaced without Signs, new Safety Signs must be applied. New Safety Signs are available from your authorized distributor or factory.

SAFETY SIGN LOCATION

The types of safety signs and locations on the equipment are shown in the illustration below. Good safety requires that you familiarize yourself with various safety signs, the type of warning and the area, or particular function related to that area, that requires your SAFETY AWARENESS.

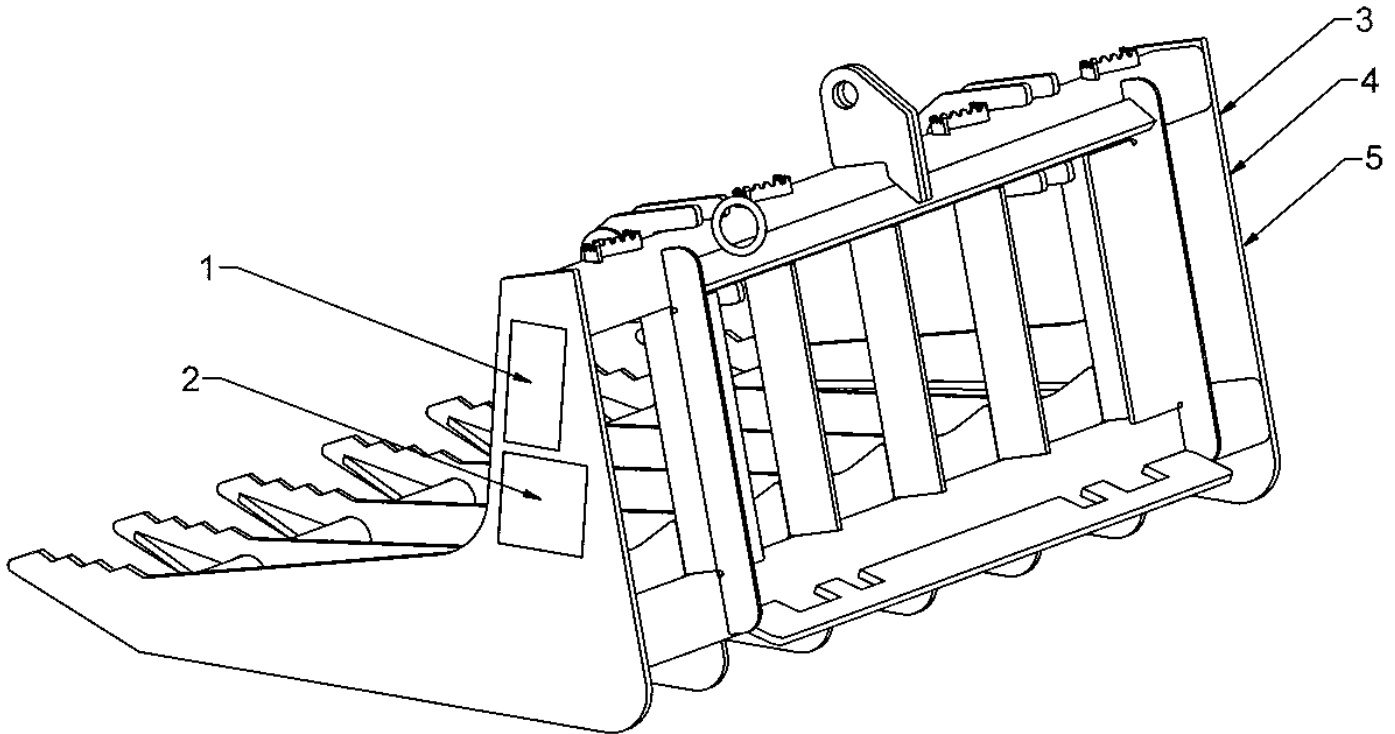

Ref. No.	Part No.	Description	No. Req'd.
1	101288	Safety Sign - Warning (Crushing and Pinching)	1
2	101289	Safety Sign - Warning (Avoid Serious Injury)	1
3	101295	Safety Sign - Warning (Crushing Hazard)	1
4	101122	Safety Sign - Warning (High-Pressure Fluid)	1
5	101296	Safety Sign - Warning (Lock Pins Installed - JD Only)	1

The model and serial number plate is located on the right side of the vertical part of the main frame.

The serial number is also stamped into the top cross tube of the mounting frame.

INSTRUCTIONS

TRACTOR AND SKID STEER REQUIREMENTS AND PREPARATION

The ETG Tine Grapple buckets are for most skid steer and tractor front loaders rated from 20 to 80 hp.

The tine buckets are designed to pick up bulky, unusually shaped, or long materials that would not stay in an ordinary bucket.

The Models ETG-5 and ETG-6 are designed to mount on skid steer units and tractor front loaders equipped with the universal quick-attach connection. The ETG-26 is a 72" wide unit with two independent grapples.

The integrated-frame tine bucket JD models are designed to fit the John Deere 200, 300, 400 and 500 series tractor front loaders. This includes Models ETG-5JD and ETG-6JD.

For skid steer attachment type models equipped with a grapple clamp, hoses and flat face couplers are included.

For the JD models, the hoses and couplers are for JD 400 and 500 series loaders equipped with the JD optional hydraulic remote outlet kit on the loader.

If your loader is not so equipped, then you will have to purchase longer hoses to connect to the remote hydraulic couplers on the rear of the tractor.

Check the power units hydraulic system. Be sure the hydraulic oil and filter have been serviced according to manufacturer's recommendations. Refer to your tractor or loader operator's manual or dealer for any adjustments necessary to put the hydraulic system in good working order.

WARNING!



- **Power unit must be equipped with ROPS or ROPS cab and seat belt. Keep seat belt securely fastened. Falling off power unit can result in death from being run over or crushed. Keep foldable ROPS systems in "locked up" position at all times.**
- **A heavy load can cause instability in driving a power unit. Make sure the rear of the tractor is properly counterbalanced with weights. Always drive slowly – especially around turns. An unstable power unit could steer badly and possibly tip over, causing injury or death.**

Always use a tractor and front loader or skid steer large enough to safely handle the material to be handled. Be sure tires and rims are in good condition. Inflate tires to the proper recommended air pressure.

Check your tractor and front loader to make sure they are in good working condition. Check all loader-mounting bolts to make sure they are tight.

Be sure tractor is properly counter-balanced with weights before attempting to lift any load with the tine bucket attachment.

The tine bucket is to be used only for handling bulky material. Do not use for digging rocks, pulling out fence, or as a craning device with a chain over the tines.

WARNING!



- **DO NOT ram into solid material piles, in ground stumps, or buried rocks. NEVER attempt to ram with the power unit and loader at high speed or full unit power. Sudden impact may result in structural failure and possible serious injury or death.**
- **Do not operate this product until you have positive indication that this attachment is securely mounted to the loader. Failure to install the lock pins or have the latching mechanism engaged could result in injury or death.**
- **Do not exceed 15 miles per hour while operating.**

INSTRUCTIONS (continued)

TINE GRAPPLE BUCKET INSTALLATION SKID STEER TYPE

Attachment to Prime Mover

WARNING!



Improper attachment of the Tine Grapple Bucket could result in injury or death. Do not operate this product until you have positive indication that the attachment is securely mounted.

1. Position the attachment on a level surface.
2. The quick attach coupler handles should be in the unlocked position with lock pins retracted, Figure 2.

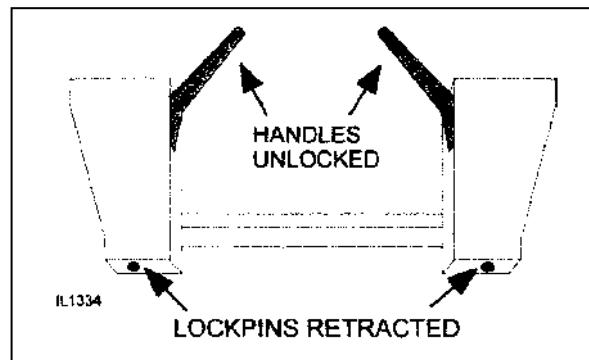

Figure 2. Quick Attach Coupler Handles - Unlocked

3. Enter the prime mover. Fasten seatbelt, start engine. Disengage the parking brake.
4. Follow the attaching procedure in the prime mover owner's manual. Align the attachment mechanism with the mounting on the grapple bucket, attach to the prime mover or loader.
5. Engage the parking brake and shut down the prime mover. Be sure to relieve pressure to the auxiliary hydraulic lines.
6. Unfasten safety restraints and exit the prime mover.
7. Make sure the hydraulic couplers are clean. Connect the hydraulic lines to the prime mover. Twist the collar of the quick couplers one-quarter turn to secure hydraulic connections. If attachment unit is being installed on a tractor loader, purchase proper couplers and hoses as required and attach to the loader as per the manufacturers instructions.
8. Engage the latching mechanism to secure attachment to loader. The lockpins must be completely extended and secured into the retaining slots provided on the attachment. Figure 3.

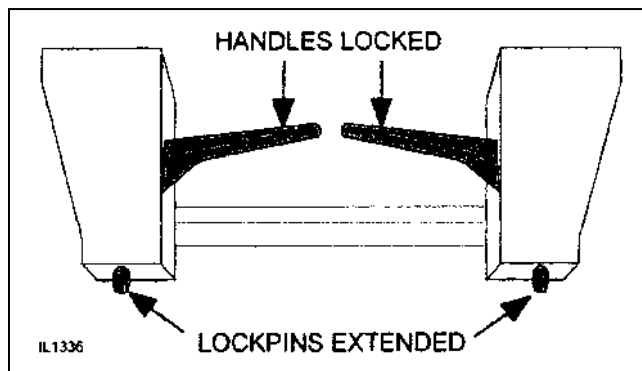

Figure 3. Attachment Coupler Handles - Locked

WARNING!



Attachment coupler handles must always be rotated to **LOCK POSITION** to prevent coupler latch from disengaging and attachment from falling off.

INSTRUCTIONS (continued)

TINE GRAPPLE BUCKET INSTALLATION SKID STEER TYPE

Attachment to Prime Mover - (continued)

9. Re-enter the primer mover. Fasten seatbelt and re-start engine.
10. Carefully raise the loader and cycle the rollback/tilt cylinders to check clearances and to ensure that the attachment is securely mounted.
11. Cycle the grapple clamp hydraulic cylinders several times full stroke to work the air out of the cylinders.

NOTICE: When shipped, the hydraulic cylinder(s) on this product contained air. Failure to remove all the air from the hydraulic cylinder(s) can cause uneven, jerky cylinder movement when the hydraulic controls are operated and possibly allow unwanted cylinder movement when those controls are not being operated.

REMOVING THE TINE GRAPPLE BUCKET

WARNING!



Serious injury or death may result from disengaging the attachment when the attachment is in an unstable position or carrying a load. Place the attachment in a stable position before disengaging.

CAUTION



Hoses for the attachment must be disconnected before the quick attach is disengaged. Pulling the attachment with the hoses could result in damage to the prime mover or the attachment.

1. If possible, find a level solid location to place the attachment. This makes it easier to disconnect and to re-connect later on.
2. Lower the attachment to the ground.
3. Engage the parking brake and shut down the prime mover. Be sure to relieve pressure to the auxiliary hydraulic lines.
4. Unfasten safety restraints and exit prime mover.
5. Disconnect the attachment hydraulic lines from the prime mover. Connect quick couplers together to keep clean.
6. Disengage attachment-locking mechanism (mechanical type).
7. Enter prime mover, fasten safety restraints and start the prime mover.
8. Disengage attachment-locking mechanism (hydraulic type).
9. Disengage the parking brake, and back away from the attachment.

INSTRUCTIONS (continued)

TINE GRAPPLE BUCKET INSTALLATION JOHN DEERE TYPE

ATTACHING AND DETACHING EQUIPMENT (200/300/400/500 SERIES LOADERS)

NOTE: Procedure is the same for all attachments. Bucket attachment shown.

ATTACHING

1. Extend bucket tilt cylinders to angle attaching brackets forward.

NOTE: Angle must be greater than that of the brackets on the rear of the tine grapple.

2. Drive forward, adjusting loader height and position until the top of the loader bracket engages the hooks (C) on the grapple.
3. Slowly retract the bucket tilt cylinders and raise the loader so the lower lock pins (F) engage the hole in the holder strap (E).
4. Continue to retract the tilt cylinders and raise the loader until the main frame of the tine grapple is vertical.
5. Engage tractor parking brake and/or place transmission in PARK. Shut off tractor engine and remove key.
6. Install the quick-lock-pin (A) into the pins (F) on each side of the grapple.
7. Connect the hydraulic hoses to the auxiliary hydraulic hook up on your loader or to the rear tractor remote outlets.
8. Start the tractor and operate the grapple clamp arm. Installation is now complete.

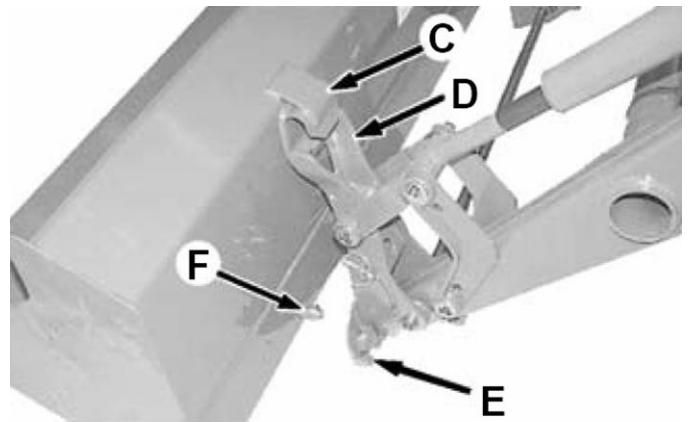

⚠ WARNING! ⚠

■ Always install the quick lock pins on the John Deere 300, 400, and 500 series loaders. Failure to install the lock pins may cause injury or death caused by falling attachment.

■ Power unit must be equipped with ROPS or ROPS cab and seat belt. Keep seat belt securely fastened. Falling off power unit can result in death from being run over or crushed. Keep foldable ROPS systems in “locked up” position at all times.

NOTE: On attachments with two pins (F), the 200, 300 and 400 series loaders will utilize the upper pin and the 500 series loader will utilize the lower pin.

INSTRUCTIONS (continued)

TINE GRAPPLE BUCKET JOHN DEERE TYPE

ATTACHING AND DETACHING EQUIPMENT (200/300/400/500 SERIES LOADERS)

NOTE: Procedure is the same for all attachments. Bucket attachment shown.

DETACHING *(without parking stands)*

1. Place transmission neutral and start engine.
2. Raise loader about 18" (460 mm) above ground level.
3. Engage tractor parking brake and/or place transmission in PARK. Shut off tractor engine and remove key.
4. Remove the quick lock-pin (A) from each side of attachment. Store pins in storage position (B).
5. Disconnect hydraulic couplers to attachment.
6. Start engine and operate bucket tilt cylinders to roll tine grapple until level, lower loader boom until attachment is on ground. Extend bucket cylinders until pin (F) releases from holder strap (E) on each side of attachment.
7. Lower loader until holder (D) releases from hook (C) on each side of attachment. Back the loader away from the attachment.
8. Set parking brake and/or place transmission in PARK. Shut off engine and remove key.

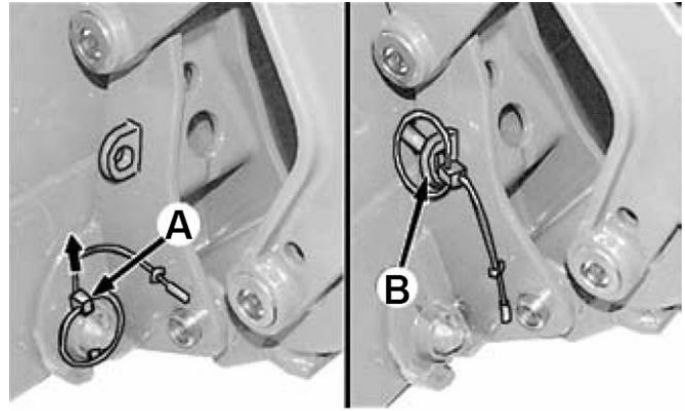

WARNING!



Serious injury or death may result from disengaging the attachment when the attachment is in an unstable position or carrying a load. Place the attachment in a stable position before disengaging.

CAUTION



Hoses for the attachment must be disconnected before the quick attach is disengaged. Pulling the attachment with the hoses could result in damage to the prime mover or the attachment.

OPERATING INSTRUCTIONS

The operator is responsible for the safe operation of this equipment. The operator must be properly trained. Operators should be familiar with the attachment, prime mover and all safety practices before starting operation. Make sure all operators have read the Owner's/Operator Manual and are familiar with the instructions and the safety rules of operation.

All reference to left, right, front, or rear are given from the operator's position, facing the direction of forward travel.

NOTE: Watch for and avoid hidden obstructions, i.e., stumps, rocks, concrete piers, or uneven slabs of concrete, when operating, or attachment damage may occur. Stop prime mover and implement immediately upon striking an obstruction. Turn off engine, remove key, inspect, and repair any damage before resuming operation.

The tine grapple buckets are designed to pick up bulky, unusually shaped, or long materials that would not stay in an ordinary bucket.

1. Approach the load so that the weight will be centered on the bottom of the bucket. The heaviest side should be closest to the back of the bucket and not near the bucket edge.
2. Before lifting, make certain the bucket is completely under the load and the bucket bottom is level or tilted back slightly.
3. Close the grapples as much as possible and lift the bucket slightly to be certain that the load is secure.

NOTE: If the load appears to be unstable, lower the bucket to the ground, open the grapple clamps and reposition the load to attain full stability. Repeat until complete stability is achieved.

When using the grapples as a rake to drag materials into position for pick up, THE GRAPPLE CLAMPS MUST BE COMPLETELY OPEN.

NOTICE: Applying a raking-type force to partially open grapple clamps will greatly magnify the fluid pressure in the hydraulic hoses, fittings, and cylinders and may cause component failure.

WARNING!



- Never heap load heavy material where the combined weight of the attachment and material could exceed the rated lifting capacity of the loader.
- Operate the attachment only when properly seated at the operator's station.
- Do not exceed the lift capacity of your loader. See loader specifications.
- Do not handle round bales.
- Be sure the load does not stick out too far in front of the bucket. A light load sticking out too far can have the same unbalanced or tipping effect as a heavy load carried in close.
- When using the grapple, lift the load slightly and make sure that the load is secure. If the load appears to be unstable, lower the load, open the grapple and reposition the load to attain full stability.
- Reduce speed when driving over rough terrain, on a slope, or turning, to avoid overturning the vehicle.
- Avoid side slope travel whenever possible. Drive up the slope to pick up a load and then down in reverse. Carry loads as close to the ground as possible.
- Before exiting the prime mover, lower the bucket to the ground, turn off the prime mover's engine, remove the key and apply the brakes.
- Do not detach loader from tractor with this attachment installed. Equip loader with materials bucket when detaching.

OPERATING INSTRUCTIONS (continued)

During Use

WARNING!



Avoid serious injury.

- **THE GRAPPLE MOVES QUICKLY!** Do not allow anyone near the grapples.
- Never get between the grapple and the bucket.
- Do not lift any load that is taller than the height of the fully opened grapple.
- Do not roll back this product so far that the load falls off toward or on the operator.
- When stacking debris or loading vehicles, make sure you are operating in an area **AWAY FROM OVERHEAD WIRES**.
- Avoid holes, ditches, and obstructions which may cause prime mover to tip.
- Never allow anyone to walk or work under a raised loader.
- Operate the loader hydraulic controls smoothly, avoiding jerky operation.
- Stop loader gradually when lowering or lifting loads.
- Be sure that people, livestock, or pets are not standing near the machine while operating.
- Do not lift or carry anyone on loader or in bucket or attachment.

Transporting the Load

WARNING!



Avoid serious injury.

- Raise the load to the minimum height required for the terrain that must be crossed with the load.
- Operate the prime mover so that the load always remains level.
- Accelerate, turn, and brake gradually.
- Avoid any obstacles, bumps, or holes in your intended path.
- Frequently check the load to make sure that the load has not become unstable.

Storage

- Storage location should be level and solid to make connecting and disconnecting easy.
- Always store in a clean, dry location away from children and livestock.
- Leaving the unit outside will materially shorten its life.
- Clean the unit thoroughly, removing all mud, dirt and grease.
- Inspect for visible signs of wear, breakage, or damage. Order any parts required, and make the necessary repairs to avoid delays when starting the next job.
- Tighten loose nuts, capscrews, and hydraulic connections.
- Cap hydraulic couplers to protect against contaminants.
- Touch up all unpainted surfaces with paint, to prevent rust.
- Coat the exposed portions of the cylinder rod with grease.
- Grease the unit.

OWNER SERVICE

WARNING!



NEVER GO UNDERNEATH EQUIPMENT. Never place any part of the body underneath equipment or between moveable parts even when the engine has been turned off. Hydraulic system leak down, hydraulic system failures, mechanical failures, or movement of control levers can cause equipment to drop or rotate unexpectedly and cause severe injury or death.

Read Manual for service instructions or have service performed by a qualified dealer.

WARNING!



Keep all persons away from operator control area while performing adjustments, service, or maintenance.

Before dismounting power unit or performing any service or maintenance, follow these steps: disengage power to equipment, lower all raised components to the ground, operate valve levers to release any hydraulic pressure, set parking brake, stop engine, remove key, and unfasten seat belt. Never leave equipment unattended with engine running.

General Information

Your attachment was designed to be almost maintenance free. Little effort is needed to keep it in top condition. It is, however, important to follow these procedures to get full performance and longevity out of the equipment.

NOTE: The grapple clamp 1.0 inch pivot bolts should have the nylock hex nut tightened only enough to remove any excess play. **DO NOT OVER-TIGHTEN THESE TWO BOLTS!**

IMPORTANT: When replacing parts, use only factory approved replacement parts. Manufacturer will not claim responsibility for use of unapproved parts or accessories and/or other damages as a result of their use.

Lubrication

The lubrication your Grapple Bucket will need is the greasing of the grapple clamp pivot. Grease fittings have been installed in each clamp pivot tube to facilitate this task.

We recommend greasing these fittings both before and after the initial eight (8) hours of use and then every (40) hours of use thereafter.

Thoroughly clean the grease zerks before servicing. Dirt mixed with lubricant will rapidly wear parts. Keep it clean.

SERVICE INSTRUCTIONS (continued)

DAILY OR EVERY 8 HOURS OF OPERATION

Replace any missing bolts or nuts with approved replacement parts.
Check hydraulic system for leaks. See procedure below.
Visually inspect the machine for worn parts or cracked welds. Repair as necessary.

WARNING!



Escaping fluid under pressure can have sufficient force to penetrate the skin, causing serious personal injury. Fluid escaping from a very small hole can be almost invisible. Use a piece of cardboard or wood, rather than hands to search for suspected leaks.

Keep unprotected body parts, such as face, eyes, and arms as far away as possible from a suspected leak. Flesh injected with hydraulic fluid may develop gangrene or other permanent disabilities.

If injured by injected fluid, see a doctor at once. If your doctor is not familiar with this type of injury, ask him or her to research it immediately to determine proper treatment.

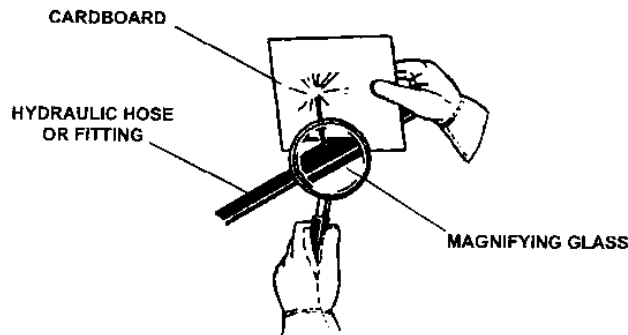

SAFETY SIGN IDENTIFICATION AND REPLACEMENT

Safety Sign placement and identification for all of the attachments can be found on the parts diagrams and lists located at the back of this manual. The safety signs are identified by their part numbers with reductions of the actual safety signs located on the page. Use this information to order replacements for missing, illegible or damaged safety signs. When replacing parts with safety signs attached, the safety sign must also be replaced. All Safety Signs are free of charge. Contact your local dealer or manufacturer for replacements.

Replacing Safety Signs

1. Clean the area of application with nonflammable solvent.
2. Wash the same area with soap and water.
3. Allow the surface to fully dry.
4. Remove the backing from the safety sign exposing the adhesive surface.
5. Apply the safety sign to the location shown in the parts diagram.
6. Smooth out any bubbles.

Helpful Hints: (1) Decals adhere to a warm surface better than a cold surface. (2) Applying heat (from a hair dryer) will greatly improve your ability to remove a damaged decal before preparing the surface for installation of a new one.

WARNING!



DO NOT MODIFY MACHINE OR ATTACHMENTS

Modifications may weaken the integrity of the and may impair the function, safety, life, and performance of the attachment. When making repairs, use only the manufacturer's genuine parts, following authorized instructions. Other parts may be substandard in fit and quality. Never modify any ROPS (Roll Over Protection Structure) or FOPS (Falling Object Protective Structure) equipment or device. Any modifications must be authorized in writing by the manufacturer.

ETG-5 and ETG-6 PARTS LIST

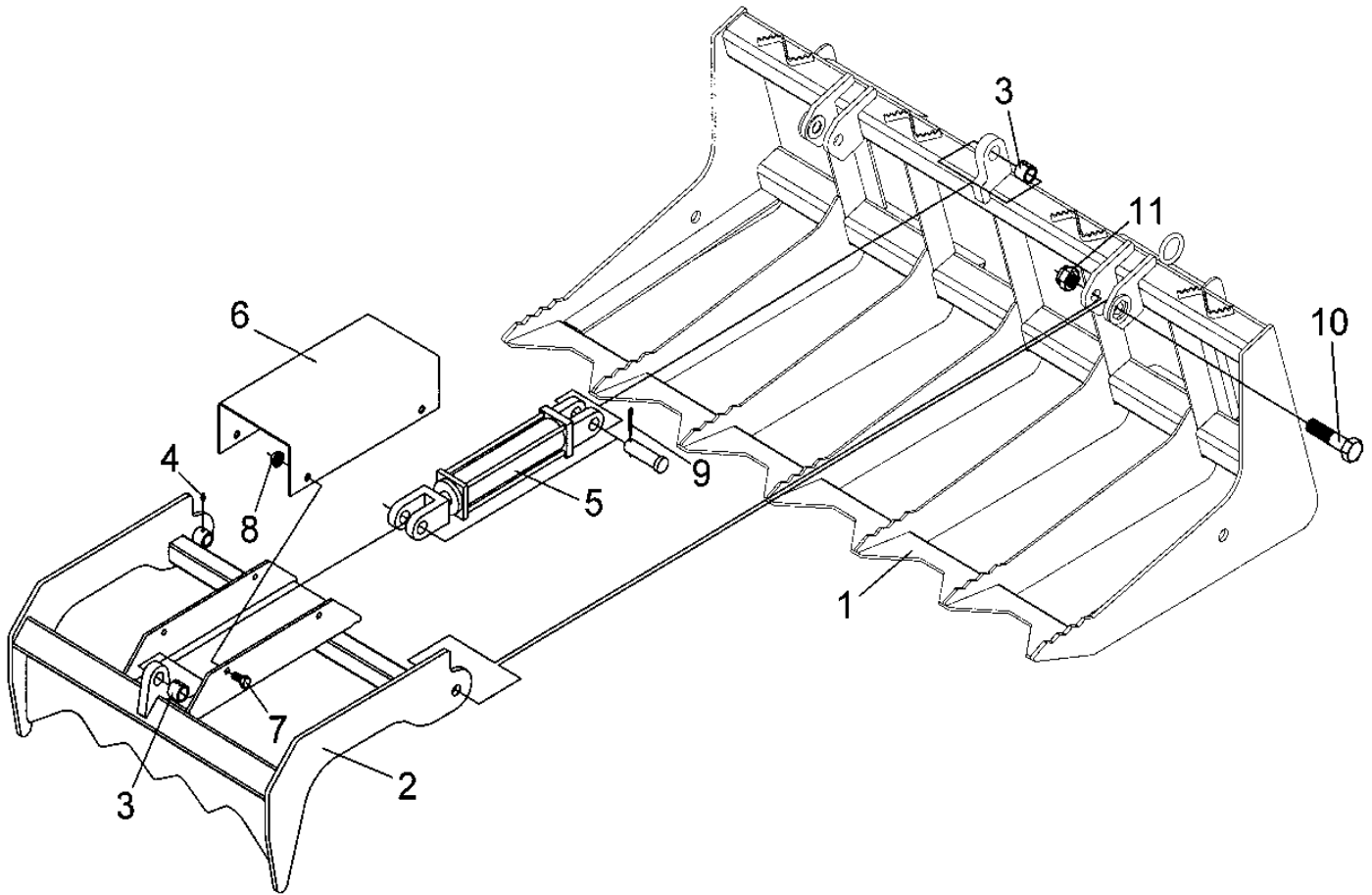

Ref. No.	Part No.	Description	No. Req'd.
1	811023	Main Frame Weldment (ETG-5)	1
	811024	Main Frame Weldment (ETG-6)	1
2	811030	Clamp Weldment w/Bushing and Zerk	1
3	2505035	Spring Bushing (1 1/4" x 1" x 1")	2
4	2504049	Drive Zerk 5/16"	2
5	2504230	Hydraulic Cylinder 2 x 8	1
6	811788	Cylinder Guard	1
7	2503062	Bolt 1/2"-13NC x 1" Hex Head Gr. 2	4
8	2500040	Nut 1/2"-13NC Whiz Flange Hex	4
9	2504121	Cotter Pin 3/16" x 1 1/2"	2
10	2503309	Bolt 1"-8NC x 4" Hex Head Gr. 5	2
11	2500085	Nut 1"-8NC Hex Jam Nylock	2
N/S	101122	Safety Sign - Warning (Hi-Pressure)	1
N/S	101288	Safety Sign - Warning (Crush/Pinch)	1
N/S	101289	Safety Sign - Warning (Injury)	1
N/S	101295	Safety Sign - Warning (Crushing Hazard)	1

ETG-5JD and ETG-6JD PARTS LIST

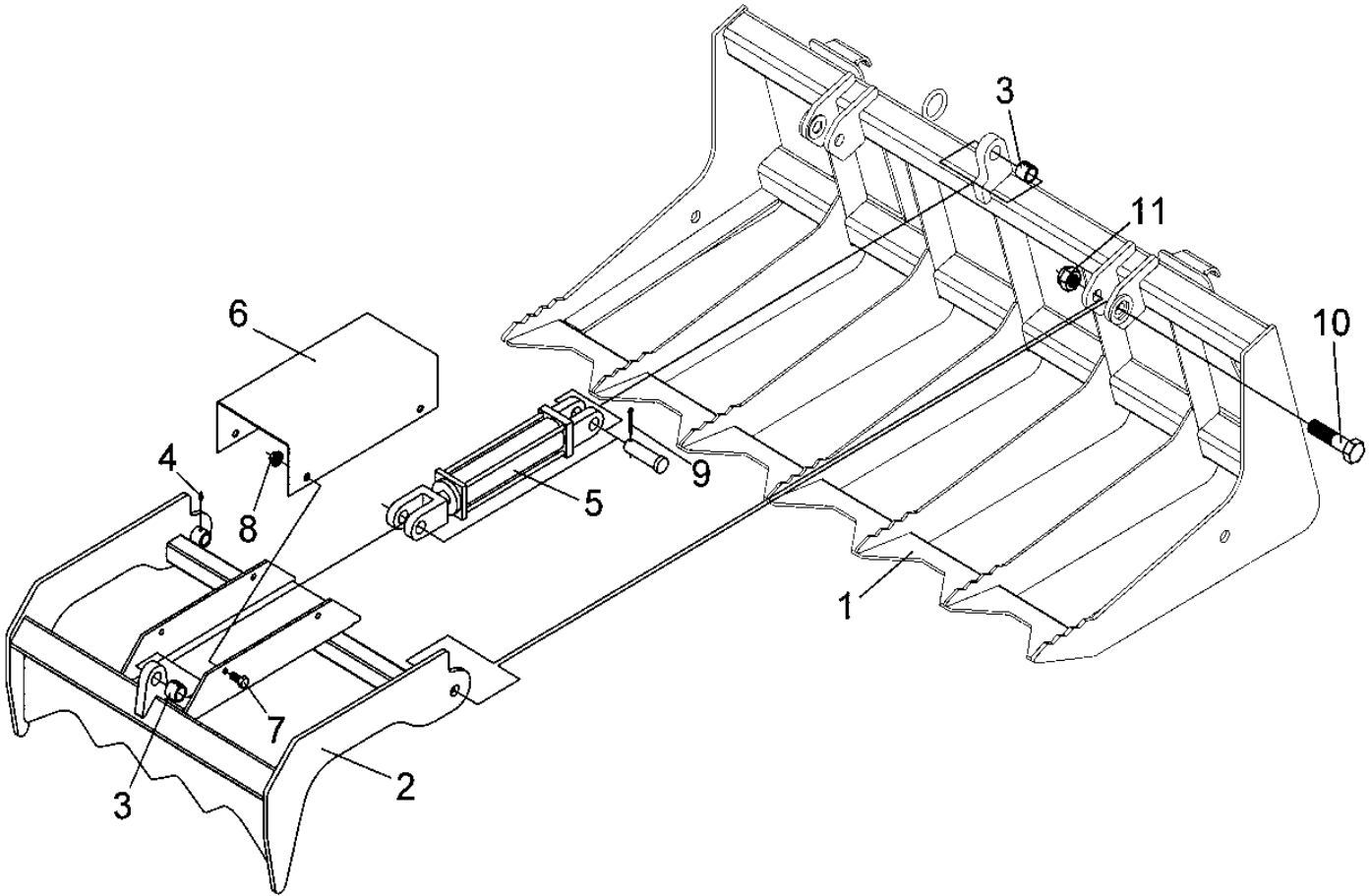

Ref. No.	Part No.	Description	No. Req'd.
1	811083	Main Frame Weldment (ETG-5JD)	1
	811087	Main Frame Weldment (ETG-6JD)	1
2	811030	Clamp Weldment w/Bushing and Zerks	1
3	2505035	Spring Bushing (1 1/4" x 1" x 1")	2
4	2504049	Drive Zerk 5/16"	2
5	2504230	Hydraulic Cylinder 2 x 8	1
6	811788	Cylinder Guard	1
7	2503062	Bolt 1/2"-13NC x 1" Hex Head Gr. 2	4
8	2500040	Nut 1/2"-13NC Whiz Flange Hex	4
9	2504121	Cotter Pin 3/16" x 1 1/2"	2
10	2503309	Bolt 1"-8NC x 4" Hex Head Gr. 5	2
11	2500085	Nut 1"-8NC Hex Jam Nylock	2
N/S	101122	Safety Sign - Warning (Hi-Pressure)	1
N/S	101288	Safety Sign - Warning (Crush/Pinch)	1
N/S	101289	Safety Sign - Warning (Injury)	1
N/S	101295	Safety Sign - Warning (Crushing Hazard)	1

ETG-26 PARTS LIST

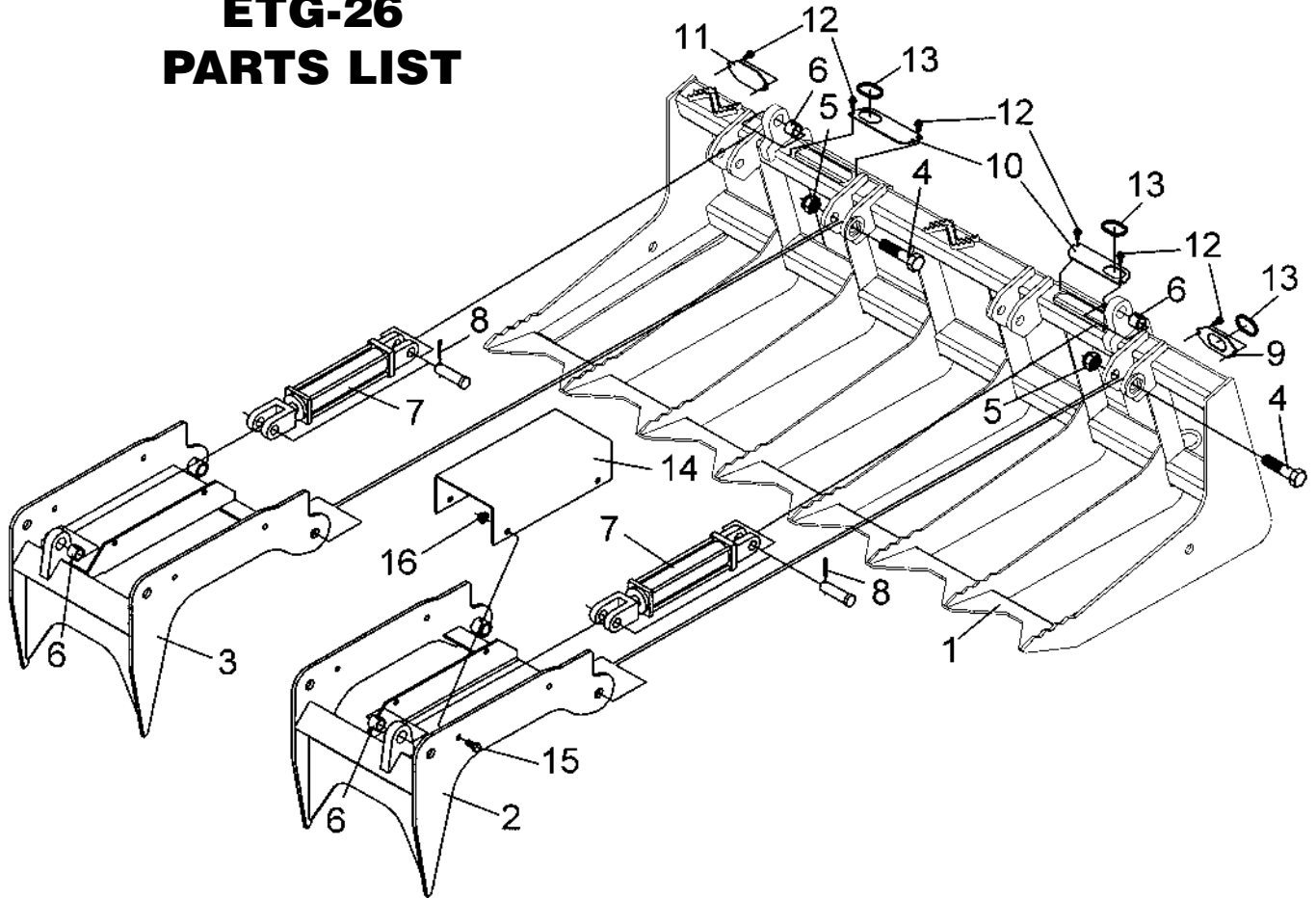

Ref. No.	Part No.	Description	No. Req'd.
1	811631	Main Frame Weldment (ETG-26)	1
2	811636	ETG Clamp, LH	1
3	811637	ETG Clamp, RH	1
4	2503309	Bolt 1"-8NC x 4" Hex Head Gr. 5	4
5	2500085	Nut 1"-8NC Hex Jam Nylock	4
6	2505035	Spring Bushing (1 1/4" x 1" x 1")	4
7	2504230	Hydraulic Cylinder 2 x 8	2
8	2504121	Pin, Cotter 3/16" x 1 1/2"	4
9	811785	Plate, Short Grommet Cover	1
10	811789	Plate, Long Grommet Cover	2
11	811797	Plate, Blank Cover	1
12	2503356	Screw, Thread Cutting 5/16"-18NC x 3/4" Slotted Hex Head	8
13	2505790	Grommet	3
14	811788	Cylinder Guard	2
15	2503062	Bolt 1/2"-13NC x 1" Hex Head Gr. 2	8
16	2500040	Nut 1/2"-13NC Whiz Flange	8
N/S	101122	Safety Sign - Warning (Hi-Pressure)	1
N/S	101288	Safety Sign - Warning (Crush/Pinch)	1
N/S	101289	Safety Sign - Warning (Injury)	1
N/S	101295	Safety Sign - Warning (Crushing Hazard)	1

HYDRAULIC DIAGRAM & PARTS LIST (ETG-5 / ETG-6)

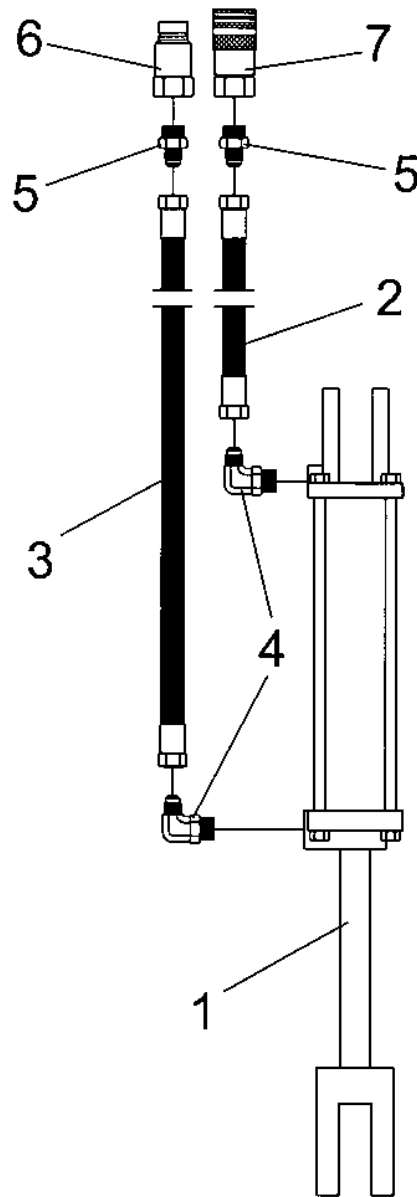

NOTE:
 These parts are for the models ETG-5 and ETG-6 with skid steer type attachment (flat face couplers).

Ref. No.	Part No.	Description	No. Req'd.
1	2504230	Hydraulic Cylinder 2 x 8	1
2	2505678	Hose, Hydraulic 1/4" ID x 72"	1
3	2505679	Hose, Hydraulic 1/4" ID x 84"	1
4	2505681	Elbow, 90° Adj. 9/16"-18 to 3/4"-16	2
5	2505684	Straight Connector 9/16"-18 to 3/4"-16	2
6	2505688	Coupling, SAE 1/2" Male - 3/4"-16 O-Ring	1
7	2505689	Coupling, SAE 1/2" Female - 3/4"-16 O-Ring	1

HYDRAULIC DIAGRAM & PARTS LIST (ETG-5JD / ETG-6JD)

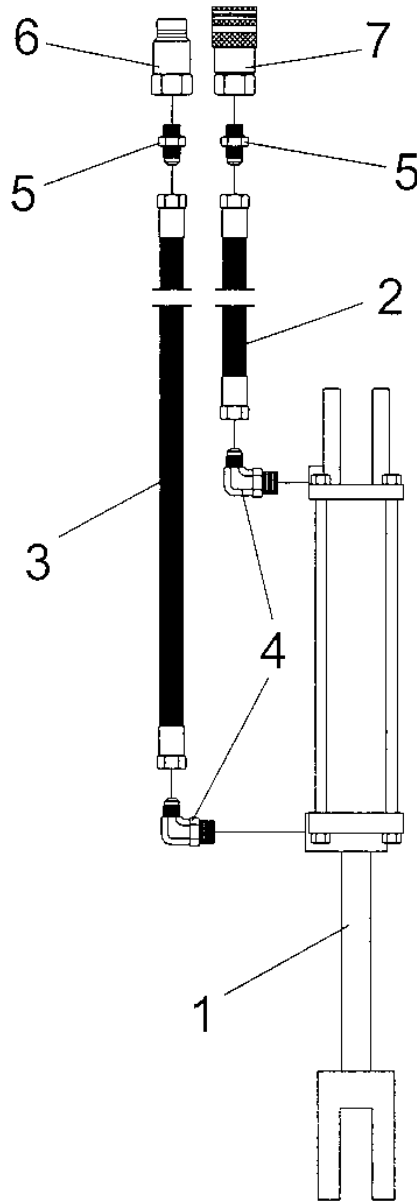

NOTE:

The hoses and couplers are for JD 400 and 500 series loaders equipped with the JD optional hydraulic remote outlet kit on the loader.

If your loader is not so equipped, then you will have to purchase longer hoses to connect to the remote hydraulic couplers on the rear of the tractor.

Ref. No.	Part No.	Description	No. Req'd.
1	2504230	Hydraulic Cylinder 2 x 8	1
2	2505678	Hose, Hydraulic 1/4" ID x 72"	1
3	2505679	Hose, Hydraulic 1/4" ID x 84"	1
4	2505681	Elbow, 90° Adj. 9/16"-18 to 3/4"-16	2
5	2505683	Straight Connector 9/16"-18	2
6	2505686	Coupling, SAE 1/4" Male - 9/16"-18 O-Ring	1
7	2505687	Coupling, SAE 1/4" Female - 9/16"-18 O-Ring	1

HYDRAULIC DIAGRAM & PARTS LIST (ETG-26)

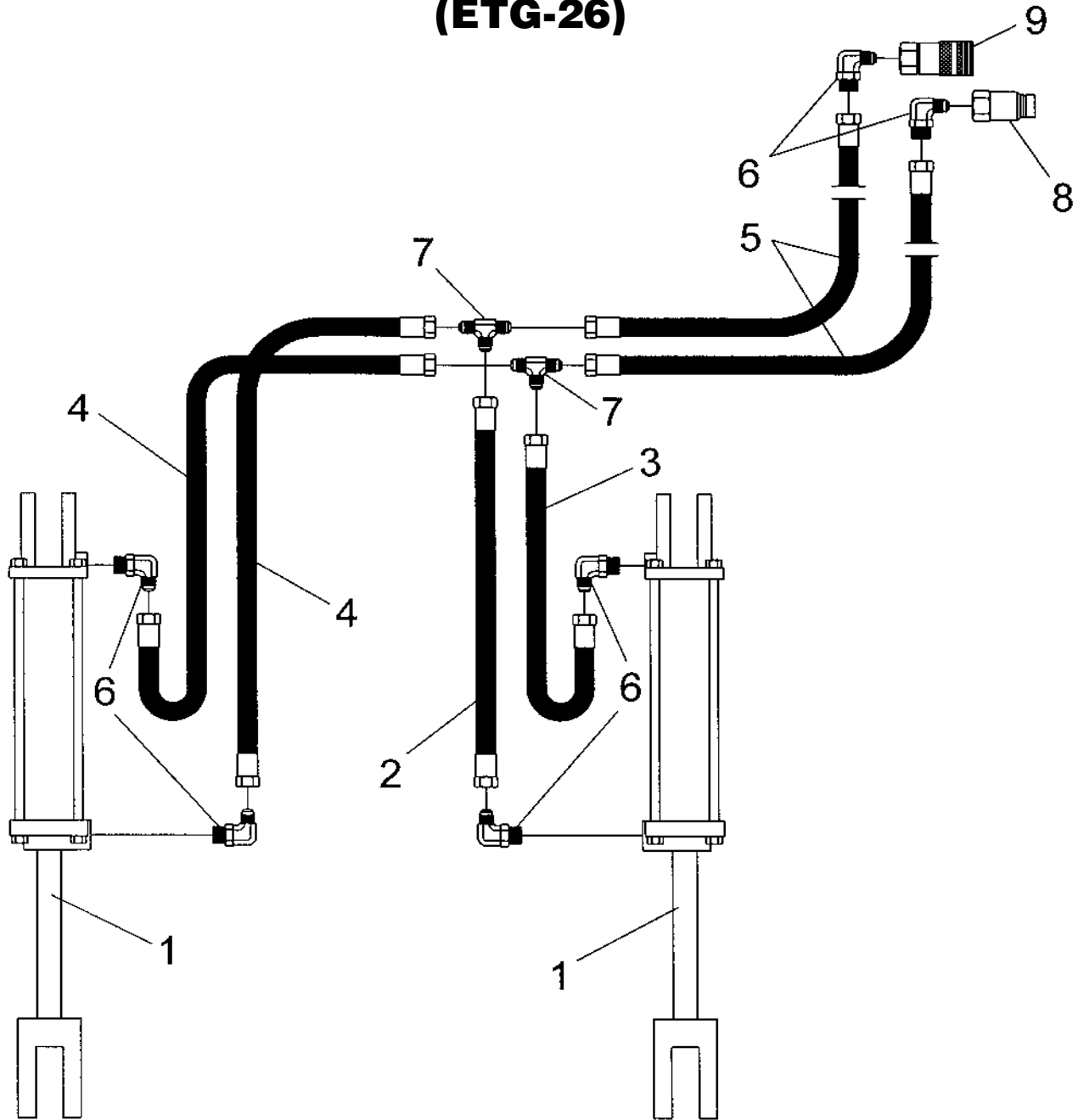

Ref. No.	Part No.	Description	No. Req'd.
1	2504230	Hydraulic Cylinder 2 x 8	2
2	2505796	Hose, Hydraulic 1/4" ID x 18"	1
3	2505794	Hose, Hydraulic 1/4" ID x 28"	1
4	2505791	Hose, Hydraulic 1/4" ID x 54"	2
5	2505679	Hose, Hydraulic 1/4" ID x 84"	2
6	2505681	Elbow, 90° Adj. 9/16"-18 to 3/4"-16	6
7	2505685	Tee, Tube 9/16"-18	2
8	2505688	Coupling, SAE 1/2" Male - 3/4"-16 O-Ring	1
9	2505689	Coupling, SAE 1/2" Female - 3/4"-16 O-Ring	1

TROUBLE-SHOOTING GUIDE

PROBLEM	POSSIBLE CAUSE	POSSIBLE REMEDY
Grapple clamp will not operate.	<ol style="list-style-type: none">1. No or insufficient oil flow.	<p>Remote hydraulic connection fittings not compatible. Check for proper fitting.</p> <p>Hydraulic system may not be supplying rated pressure. Consult your dealer.</p> <p>Hydraulic system may not be delivering its rated volume of oil due to wear. Hydraulic pump may need to be repaired.</p> <p>Hydraulic valve on tractor or skid steer not engaged.</p>
Material slips from grapple clamp grasp.	<ol style="list-style-type: none">1. Clamp arms not positioned correctly on material.2. Not firmly clamped by hydraulic cylinder.3. Hydraulic system has leak – allowing clamping pressure to back off.	<p>Reposition clamp arms.</p> <p>Operate hydraulic cylinder to clamp tighter.</p> <p>Find leak and repair (could be O-Ring in valve).</p>
Loader tilt cylinders won't pull back after tilting forward.	<ol style="list-style-type: none">1. Loader too small for weight of material being handled.2. Hydraulic system not operating at correct pressure.	<p>Use larger power unit with larger size loader.</p> <p>Check pressure and adjust or repair.</p>
Excessive rear tractor tire slippage.	<ol style="list-style-type: none">1. Tractor too small.2. Insufficient traction.	<p>Use larger, heavier tractor or reduce amount handled.</p> <p>Add rear tire weights or add ballast in tire. Use tractor with FWDA.</p> <p>Attach heavy implement on rear of tractor for counter weight.</p>
Bent lower main frame tines.	<ol style="list-style-type: none">1. Improper operation.	<p>Operator ramming into hard packed piles, in-ground stumps or rocks – retrain operator.</p> <p>Operating in frozen ground – trying to loosen material too large to be handled.</p>

TROUBLE-SHOOTING GUIDE (continued)

PROBLEM	POSSIBLE CAUSE	POSSIBLE REMEDY
Hydraulic hose failure.	1. Hydraulic relief pressure setting is very high and may cause hydraulic hose failure.	Check hydraulic system and adjust relief valve.
	2. Hoses are worn or frayed.	Replace hose.
	3. Hose rating may be too low for hydraulic system pressure.	Replace with higher rated hoses.
	4. Hose is being pinched by movement of loader mount or loader linkage.	Reroute hose and refasten.
Hydraulic oil overheats.	1. Hydraulic oil level in prime mover may be low.	Check and add oil.
	2. Hydraulic oil or oil filter in prime mover may be dirty.	Change oil and filter according to power unit manufacturer's recommendations.
	3. Hydraulic oil reservoir of prime mover may be small.	Allow time for oil to cool down.
Tine bucket is loose on loader.	1. Attachment not correct.	Tine bucket mount may not be properly latched on loader. Check lock pins.

SAFETY REQUIREMENTS

AVOID ACCIDENTS BY FOLLOWING ALL OF THE SAFETY REQUIREMENTS LISTED BELOW.

- Machinery should be operated only by those who are responsible and are authorized to do so.
- Stop the engine, lower all equipment, lock the brakes, and remove the ignition key before dismounting from the skid steer or tractor.
- Never stand between skid steer and attachment while power unit is being connected to the attachment.
- Loose fitting clothing should not be worn, to avoid catching on various parts.
- Detach attachment in area where children normally do not play.
- When performing adjustments or maintenance on an attachment, first lower it to the ground or block it securely at a workable height.
- Only a qualified operator should be permitted on power unit when in operation; no riders allowed.
- Make certain everyone is in the clear before starting power unit or raising or lowering equipment.
- Operate the power unit and attachment only while seated in the driver's seat.
- Reduce speed when transporting mounted attachments to avoid bouncing and momentary loss of steering control.
- A heavy load can cause instability of the power unit. Use extreme care during road travel. Slow down on turns and watch out for bumps. Power unit may need counterweights to counter-balance the weight of the attachment.
- Reduce speed on hillsides or curves so there is no danger of tipping.
- Avoid driving too close to the edge of ditches or drop offs.
- Do not transport implement on public roads without reflectors and slow moving vehicle emblem in daylight and with approved warning lights at night and other periods of poor visibility.
- Keep work area clear of all debris. Never assume an area is clear. ALWAYS CHECK.
- Check to make certain there are no buried utilities in the work area before starting work.
- Keep alert and watch the front as well as the rear when working with the attachment.

OWNER'S/ OPERATOR'S MANUAL

MODEL NO.'s

ETG-5

ETG-6

ETG-5JD

ETG-6JD

ETG-26

MARCH 2015

TINE GRAPPLE BUCKETS for Skid Steer and Tractor Front Loaders

WHEN ORDERING REPAIR PARTS,
ALWAYS GIVE THE FOLLOWING INFORMATION:

1. PART NUMBER
2. PART DESCRIPTION
3. MODEL NUMBER
4. NAME OF ITEM

**MAKE EVERY DAY A
HOLIDAY FROM ACCIDENTS!**

WORKSAVER, INC.

P.O. BOX 100 LITCHFIELD, IL 62056-0100 (217) 324-5973
WEB: <http://www.worksaver.com> E-MAIL: sales@worksaver.com