

OWNER'S/  
OPERATOR'S  
MANUAL

MODEL NO.'s

PF-448

SSPF-3748

SSPF-3755

SSPF-442

SSPF-448

SSPF-5548

GLPF-442

GLPF-448

GLPF-5548

JDPF-5442

JDPF-5448

JDPF-6748

JDPF-H48048

JDPF-H48060

 **CAUTION**

For Safe Operation  
Read Rules And  
Instructions Carefully

SI NO LEEINGLES, PIDA AYUDA  
A AIGUIEN QUE SI LO LEA  
PARA QUE LE TRADUZCA LAS  
MEDIDAS DE SEGURIDAD.

# PALLET FORK

## FOR SKID STEER TRACTOR FRONT LOADERS

Safety Instructions  
Tractor Preparation  
Operating Instructions

Assembly & Mounting  
Maintenance  
Repair Parts

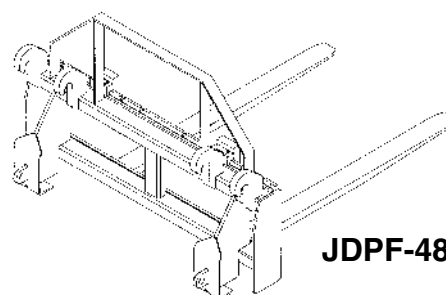
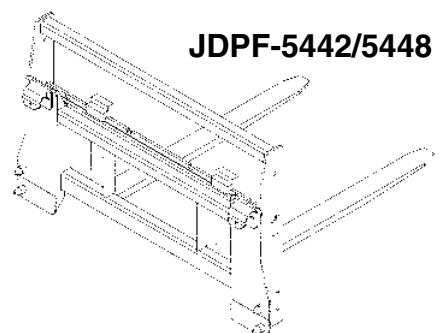
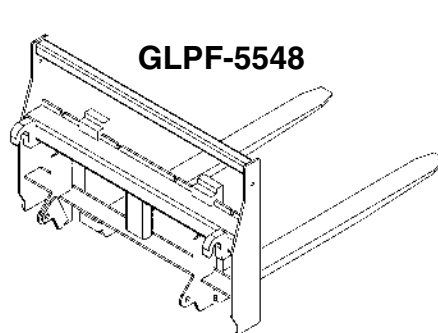
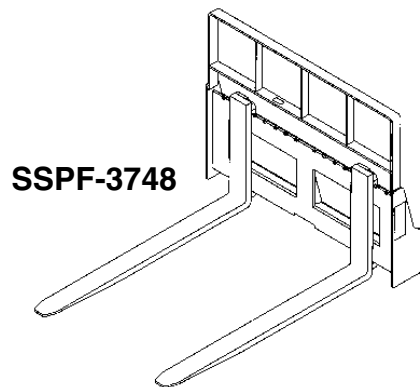
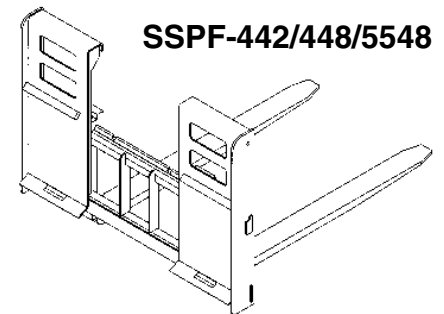
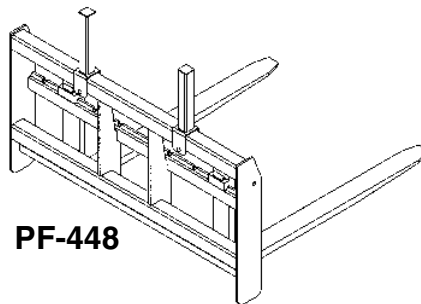

# TABLE OF CONTENTS

SI NO LEEINGLES, PIDA AYUDA A  
AIGUIEN QUE SI LO LEA PARA QUE  
LE TRADUZCA LAS MEDIDAS DE  
SEGURIDAD.

WARRANTY .....	2
SAFETY INFORMATION .....	3 - 10
SAFETY SIGNS .....	11
INSTRUCTIONS .....	12 - 20
PARTS DRAWINGS/LISTS .....	21 - 27

## STATEMENT OF POLICY

It is the policy of Worksaver, Inc. to improve its products where it is possible and practical to do so. Worksaver, Inc. reserves the right to make changes or improvements in design and construction at any time, without incurring the obligation to make these changes on previously manufactured units.

## TO THE OWNER:

Read this manual before using your Pallet Fork. This manual is provided to give you the necessary operating and maintenance instructions for keeping your Loader Fork in top operating condition. Please read this manual thoroughly. Understand what each control is for and how to use it. Observe all safety signs on the machine and noted throughout the manual for safe operation of implement. Keep this manual handy for ready reference.

Like all mechanical products, it will require cleaning and upkeep.

Use only genuine Worksaver, Inc. service parts. Substitute parts will void the warranty and may not meet standards required for safe and satisfactory operation. Record the model and serial number of your Pallet Fork here:

Model: \_\_\_\_\_ Serial Number: \_\_\_\_\_

---

---

## RETAIL CUSTOMER'S RESPONSIBILITY

**It is the Retail Customer and/or Operator's responsibility to read the Operator's Manual, to operate, lubricate, maintain, and store the product in accordance with all instructions and safety procedures. Failure of the operator to read the Operator's Manual is a misuse of this equipment.**

**It is the Retail Customer and/or Operator's responsibility to inspect the product and to have any part(s) repaired or replaced when continued operation would cause damage or excessive wear to other parts or cause a safety hazard.**

**It is the Retail Customer's responsibility to deliver the product to the authorized Worksaver Dealer, from whom he purchased it, for service or replacement of defective parts which are covered by warranty. Repairs to be submitted for warranty consideration must be made within forty-five (45) days of failure.**

**It is the Retail Customer's responsibility for any cost incurred by the Dealer for traveling to or hauling of the product for the purpose of performing a warranty obligation or inspection.**

# **LIMITED WARRANTY**

Worksaver warrants to the original purchaser of any new Pallet Fork (Models PF-448, SSPF-3748, SSPF-3755, SSPF-442, SSPF-448, SSPF-5548, JDPF-5442, JDPF-5448, JDPF-6748, JDPF-48048, JDPF-48060, GLPF-442, GLPF-448 and GLPF-5548), that the equipment be free from defects in material and workmanship for a period of six (6) months for non-commercial, state, and municipalities. Use sixty (60) days for commercial use from date of retail sale.

Replacement or repair parts installed in the equipment covered by this warranty are warranted for sixty (60) days from the date of purchase of such part or to the expiration of the applicable new equipment warranty period, whichever occurs later.

Such parts shall be provided at no cost to the user during regular working hours. Worksaver reserves the right to inspect any equipment or parts which are claimed to have been defective in material or workmanship.

## **DISCLAIMER OF IMPLIED WARRANTIES & CONSEQUENTIAL DAMAGES**

Worksaver's obligation under this warranty, to the extent allowed by law, is in lieu of all warranties, implied or expressed, including implied warranties of merchantability and fitness for a particular purpose and any liability for incidental and consequential damages with respect to the sale or use of the items warranted. Such incidental and consequential damages shall include but not be limited to: transportation charges other than normal freight charges; cost of installation other than cost approved by Worksaver; duty; taxes; charges for normal service or adjustments; loss of crops or any other loss of income; rental of substitute equipment, expenses due to loss, damage, detention or delay in the delivery of equipment or parts resulting from acts beyond the control of Worksaver.

## **THIS WARRANTY SHALL NOT APPLY:**

1. To vendor items which carry their own warranties, such as hydraulic cylinders, tires, and tubes.
2. If the unit has been subjected to misapplication, abuse, misuse, negligence, fire or other accident.
3. If parts not made or supplied by Worksaver have been used in connection with the unit, if, in sole judgement of Worksaver such use affects its performance, stability, or reliability.
4. If the unit has been altered or repaired outside of an authorized Worksaver dealership in a manner which, in the sole judgement of Worksaver affects its performance, stability or reliability.
5. To normal maintenance service and normal replacement items such as bent forks, hydraulic fluid, worn blades, or to normal deterioration of such things as belts and exterior finish, due to use or exposure.
6. To expendable or wear items such as teeth, chains, sprockets, latch parts, springs and other items that in the company's sole judgement is a wear item.

NO EMPLOYEE OR REPRESENTATIVE OF WORKSAVER IS AUTHORIZED TO CHANGE THIS WARRANTY IN ANY WAY OR GRANT ANY OTHER WARRANTY UNLESS SUCH CHANGE IS MADE IN WRITING AND SIGNED BY WORKSAVER'S SERVICE MANAGER, POST OFFICE BOX 100, LITCHFIELD, ILLINOIS 62056-0100.

# To the Owner/Operator/Dealer

All implements with moving parts are potentially hazardous. There is no substitute for a cautious, safe-minded operator who recognizes the potential hazards and follows reasonable safety practices. The manufacturer has designed this implement to be used with all its safety equipment properly attached to minimize the chance of accidents.

## BEFORE YOU START!!

**Read the safety messages on the implement and shown in your manual.  
Observe the rules of safety and common sense!**



**THIS SYMBOL MEANS**

- ATTENTION!
- BECOME ALERT!
- YOUR SAFETY IS INVOLVED!

THIS SAFETY ALERT SYMBOL IDENTIFIES IMPORTANT SAFETY WARNING MESSAGES. CAREFULLY READ EACH WARNING MESSAGE THAT FOLLOWS. FAILURE TO UNDERSTAND AND OBEY A SAFETY WARNING, OR RECOGNIZE A SAFETY HAZARD, COULD RESULT IN AN INJURY OR DEATH TO YOU OR OTHERS AROUND YOU. THE OPERATOR IS ULTIMATELY RESPONSIBLE FOR THE SAFETY OF HIMSELF, AS WELL AS OTHERS, IN THE OPERATING AREA OF THE TRACTOR AND EQUIPMENT.

---

## UNDERSTAND SIGNAL WORDS



**DANGER**

Indicates an imminently hazardous situation that, if not avoided, WILL result in DEATH OR VERY SERIOUS INJURY.



**WARNING**

Indicates a imminently hazardous situation that, if not avoided, COULD result in DEATH OR SERIOUS INJURY.



**CAUTION**

Indicates a imminently hazardous situation that, if not avoided, MAY result in MINOR INJURY.

**IMPORTANT**

Identifies special instructions or procedures that, if not strictly observed, could result in damage to, or destruction of the machine, attachments or the environment.

**NOTE:** *Identifies points of particular interest for more efficient and convenient operation or repair.*

If you have questions not answered in this manual or require additional copies or the manual is damaged, please contact your dealer or the manufacturer directly.

---

## Important Safety Information!

Working with equipment can lead to injuries. Read this manual, and the manual for your tractor, before assembly or operating, to acquaint yourself with the machine. It is the equipment owner's responsibility, if this equipment is used by any person other than yourself, is loaned or rented, to make certain that the operator, prior to operating:

1. Reads and understands the operator's manuals.
2. Is instructed in safe and proper use.











The use of this equipment is subject to certain hazards which cannot be protected against by mechanical means or product design. All operators of this equipment must read and understand this entire manual, paying particular attention to safety and operating instructions, prior to using. If there is something in this manual you do not understand, ask your supervisor, or your dealer, to explain it to you.

# SAFETY INSTRUCTIONS (continued)



## EQUIPMENT SAFETY GUIDELINES

Safety of the operator is one of the main concerns in designing and developing a new piece of equipment. Designers and manufacturers build in as many safety features as possible. However, every year many accidents occur which could have been avoided by a few seconds of thought and a more careful approach to handling equipment. You, the operator, can avoid many accidents by observing the following precautions in this section. To avoid personal injury, study the following precautions and insist those working with you, or for you, follow them. Review the safety instructions with all users annually.

-  This equipment is dangerous to children and persons unfamiliar with its operation. The operator should be a responsible adult familiar with farm machinery and trained in this equipment's operations. **Do not allow persons to operate or assemble this unit until they have read this manual and have developed a thorough understanding of the safety precautions and of how it works.**
  
-  Never use alcoholic beverages or drugs which can hinder alertness or coordination while operating this equipment. Consult your doctor about operating this machine while taking prescription medications.
  
-  Replace any CAUTION, WARNING, DANGER or instruction safety sign that is not readable or is missing. Location of such safety signs is indicated in this booklet. Do not paint over, remove or deface any safety signs or warning signs on your equipment. Observe all safety signs and practice the instruction on them.
  
-  Only use a power unit equipped with a ROPS cab or rollover protective structure. Keep foldable ROPS systems in "locked up" position at all times. Keep seat belt fastened.
  
-  Never exceed the limits of a piece of machinery. If its ability to do a job, or to do so safely, is in question – **DON'T TRY IT.**
  
-  Do not modify the equipment in any way. Unauthorized modification may impair the function and/or safety and could affect the life of the equipment.
  
-  Know your controls and how to stop skid steer, tractor, engine, and loader quickly in an emergency. Read this manual and the one provided with your tractor or skid steer.
  
-  In addition to the design and configuration of this implement, including Safety Signs and Safety Equipment, hazard control and accident prevention are dependent upon the awareness, concern, prudence, and proper training of personnel involved in the operation, transport, maintenance, and storage of the machine. Refer also to Safety Messages and Operation Instructions in each of the appropriate sections of the Tractor, Skid Steer, and Implement Manuals. Pay close attention to the Safety Signs affixed to the Tractor, Skid Steer, and the Implement.

# SAFETY INSTRUCTIONS (continued)



## OPERATIONAL SAFETY



Start prime mover only when properly seated in the operator's seat. Starting a prime mover in gear can result in injury or death. Do not mount or dismount while the prime mover is moving. Mount or dismount only when the prime mover and all moving parts are completely stopped.



Operate the prime mover and/or implement controls only while properly seated in the prime mover's seat with the seat belt securely fastened around you. Inadvertent movement of the tractor or implement may cause serious injury or death.



Keep all helpers and bystanders twenty-five feet (25') from an operating power unit and attached equipment. Only properly trained people should operate this machine. It is recommended the tractor be equipped with a Rollover Protection System (ROPS) and a seat belt that is used. Always stop the tractor, skid steer, or forklift, set brake, shut off the engine, remove the ignition key, and lower loader and attachment to the ground before dismounting. Never leave equipment unattended with the engine running.



Please remember it is important that you read and heed the safety signs on the front loader attachment and loader, and the safety rules set forth. Clean or replace all safety signs if they cannot be clearly read and understood. They are there for your safety as well as the safety of others. The safe use of this machine is strictly up to you, the operator.



Be sure power unit is in good condition. Read all the safety precautions and make sure all operators are familiar with the safety rules of operation.



Never leave the prime mover and implement unattended while the implement is in the lifted position. Accidental operation of lifting lever or a hydraulic failure may cause sudden drop of unit with injury or death by crushing.



When the use of hand tools is required to perform any part of assembly, installation, adjustment, maintaining, repairing, removal, or moving the implement, be sure the tools used are designed and recommended by the tool manufacturer for that specific task.



Never allow children to play on or around prime mover or implement. Children can slip or fall off the equipment and be injured or killed. Inadvertent contact with controls can cause the implement to shift or fall crushing themselves or others.



Always use two people to handle heavy, unwieldy components during assembly, installation, removal, or moving the loader attachment.



Never place any part of your body where it would be in danger if movement should occur during assembly, installation, operation, maintaining, repairing, removal, or moving the implement.



The use of any loader attachment is NOT recommended on tractor with a tricycle wheel arrangement. Tricycle type tractors are unstable for front loader use.

















A heavy load can cause instability in driving a power unit. Make sure the front or rear of the power unit is properly counter-balanced with weights. Always drive slowly – especially around turns. An unstable power unit could steer badly and possibly tip over, causing injury or death.

# SAFETY INSTRUCTIONS (continued)



## OPERATIONAL SAFETY (continued)

-  Do not allow children or others to ride on the power unit with an operator. Riders are subject to injury such as being struck by foreign objects or being thrown off. Riders obstruct the operator's view resulting in unsafe operation. **Never allow anyone to ride on the implement!**
-  Before you operate any equipment, check over all pins, bolts and connections to be sure all are securely in place. Replace any damaged or worn parts immediately.
-  Check that this attachment is securely mounted to the loader. Failure to install lock pins or have the latching mechanism engage could result in injury or death.
-  Do not work under a raised loader unless it is securely blocked or held in position. Do not depend on the power unit hydraulic system to hold the implement in place.
-  Operate the loader controls smoothly, avoiding jerky operation. Stop loader gradually when lowering or lifting loads.
-  Beware of low electrical wires when loader is raised. Serious injury or death can result if contact is made.
-  Do not lift round bales.
-  When handling material on a slope, always approach the material with the power unit facing uphill.
-  When stacking material, **ALWAYS MAKE SURE MATERIAL IS PLACED SO THE STACK IS STABLE.**
-  Keep all bystanders at a safe distance. **REMEMBER FALLING ITEMS CAN ROLL OR TUMBLE.**
-  Do not handle loads that exceed the weight limitations of the loader or forks.
-  Carry the loads slowly and as low as possible to the ground. Avoid excessive speed during operation.
-  Completely engage load before lifting. Fork length should be at least two-thirds of load length. It is recommended to keep lifting surface of the forks level at all times. When backward tilt is required to stabilize the load, use extreme caution.
-  Keep alert and watch the rear as well as the front when working with the loader. Beware of lift clearance when raising loader to maximum height.

# SAFETY INSTRUCTIONS (continued)



## OPERATIONAL SAFETY (continued)



Be certain the power unit is in neutral or park position before starting engine.



Always shut off power unit and shift to “Park” or set brakes when leaving unit. Always lower bucket or attachment to ground, relieve all hydraulic pressure. Remove key when leaving equipment unattended. Park in level area.



Do not use the fork tines for prying or any purpose other than lifting.



Use extreme care when working on inclines and hillsides. Do not operate close to ditches, creeks or holes. Slow down when operating over rough ground.



When maneuvering close to buildings or passing through narrow areas, be sure to allow sufficient clearance for the power unit, loader, and load. Drive slowly. Allow for additional length of loader and load on power unit while turning.



Keep load centered on attachment and loader. Unbalanced loads increase possibility of tipping or roll-over. Secure the load properly. Unsecured loads can fall unexpectedly.



Never lift a load with one fork.



Be sure that people, livestock, or pets are not standing near the machine while operating. Never allow anyone to walk or work under a raised loader.



Do not lift or carry anyone on loader or in bucket or on attachment. Do not use loader for a work platform.



ALWAYS lower loader to the ground or block securely before performing any maintenance work.



Always keep power unit on solid footing when operating loader.



Observe Safety Recommendations in loader instruction manual.

















Inspect the entire machine periodically as indicated in the Maintenance Section of this manual. Look for loose fasteners, worn or broken parts, pinched hydraulic hoses, and leaky or loose fittings. Make sure all pins have cotter pins and washers. Serious injury may occur from not maintaining this machine in good working order.



# SAFETY INSTRUCTIONS (continued)



## TRANSPORT SAFETY

-  Comply with state and local laws governing highway safety and movement of farm machinery on public roads.
-  The use of flashing amber lights is acceptable in most localities. However, some localities prohibit their use. Local laws should be checked for all highway lighting and marking requirements.
-  When driving the tractor and equipment on the road or highway under 20 mph (32 kph) at night or during the day, use flashing amber warning lights and a slow moving vehicle (SMV) identification emblem.
-  Always be sure the implement is in the proper raised position for transport.
-  Reduce speed when transporting mounted implements to avoid bouncing and momentary loss of steering control.
-  Plan your route to avoid heavy traffic.
-  Do not drink and drive!
-  Watch for traffic when operating near or crossing roadways.
-  Turn curves or go up or down hills only at a low speed and at a gradual steering angle. Make certain that at least 20% of the tractor's weight is on the front wheels to maintain safe steering. Slow down on rough or uneven surfaces, and loose gravel.
-  Use extreme care and maintain minimum ground speed when transporting on hillside, over rough ground and when operating close to ditches or fences. Be careful when turning sharp corners.
-  Never allow riders on either power unit or implement. Falling off can kill.
-  Be a safe and courteous driver. Always yield to oncoming traffic in all situations, including narrow bridges, intersections, etc.
-  Do not exceed 20 mph (32 kph). Reduce speed on rough roads and surfaces.
-  Always disengage PTO before driving the tractor to transport the implement from one place to another.

# SAFETY INSTRUCTIONS (continued)



## MAINTENANCE SAFETY

**Good maintenance is your responsibility. Poor maintenance is an invitation to trouble.**



Before working on this machine, drive to a level area, disengage the PTO, lower implement or loader (or if working underneath, raise and block securely), shut off the engine, relieve all hydraulic pressure, set the brakes, and remove the ignition keys.



Never work under equipment unless it is blocked securely. Never depend on hydraulic system to keep implement in raised position.



Do not use blocking made of concrete blocks, logs, buckets, barrels or any other material that could suddenly collapse or shift positions. Use only good quality blocking material.



Never operate controls from the ground. Operate the controls only from the operator's station.



Keep all persons away from operator control area while performing adjustments, service, or maintenance.



Always use personal protection devices such as eye, hand and hearing protectors, when performing any service or maintenance.



Periodically tighten all bolts, nuts and screws and check that all cotter pins are properly installed to ensure unit is in a safe condition.



Check to ensure all safety signs are installed and in good condition.







Openings in the skin and minor cuts are susceptible to infection from hydraulic fluid. If injured by escaping hydraulic fluid, see a doctor at once. Gangrene and death can result. Without immediate medical treatment, serious infection and reactions can occur.

**If equipment has been altered in any way from original design, the manufacturer does not accept any liability for injury or warranty.**

# SAFETY INSTRUCTIONS (continued)



## STORAGE SAFETY

-  Following operation or when unhooking, stop the tractor, set the brakes, shut off the engine, relieve all hydraulic pressure and remove the ignition keys.
-  Store the unit in an area away from human activity. Do not permit children to play on or around the stored unit.
-  Do not park equipment where it will be exposed to livestock for long periods of time. Damage and livestock injury could result.
-  Make sure all parked machines are on a hard, level surface and engage all safety devices. Storage location should be level and solid to make connecting and unconnecting to power unit easy.
-  If blocking is used, make sure it is solid and secure before leaving area.



## SAFETY SIGNS

Keep safety signs clean and legible at all times.

Replace safety signs that are missing or have become illegible.

Replaced parts that displayed a safety sign should also display the current sign.

Safety signs are available from your Distributor or Dealer Parts Department or the factory.

### **How to Install Safety Signs:**

Be sure that the installation area is clean and dry. Be sure temperature is above 50°F (10°C).

Decide on the exact position before you remove the backing paper.

Remove the smallest portion of the split backing paper. Align the sign over the specified area and carefully press the small portion with the exposed sticky backing in place.

Slowly peel back the remaining paper and carefully smooth the remaining portion of the sign in place. Small air pockets can be pierced with a pin and smoothed out using the piece of sign backing paper.

# SAFETY SIGNS

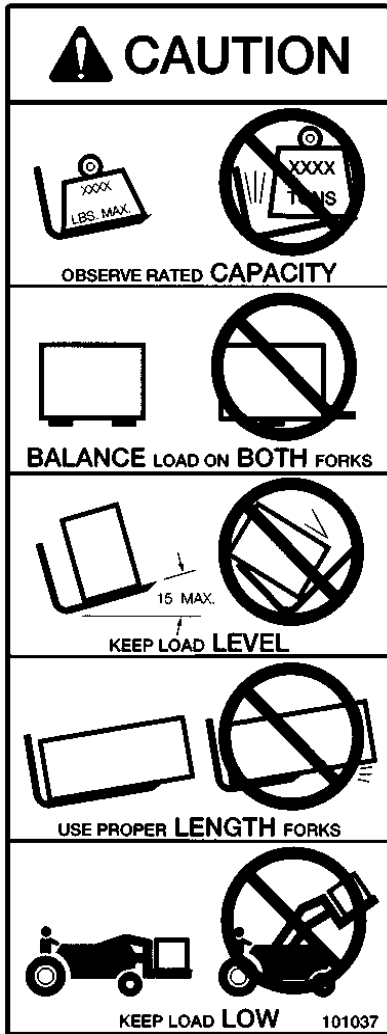

## BE CAREFUL!

Use a clean, damp cloth to clean safety decals. Avoid spraying too close to decals when using a pressure washer; high-pressure water can enter through very small scratches or under edges of decals causing them to peel or come off.

## REMEMBER:

If Safety Signs have been damaged, removed, become illegible or parts replaced without Signs, new Safety Signs must be applied. New Safety Signs are available from your authorized distributor or factory.

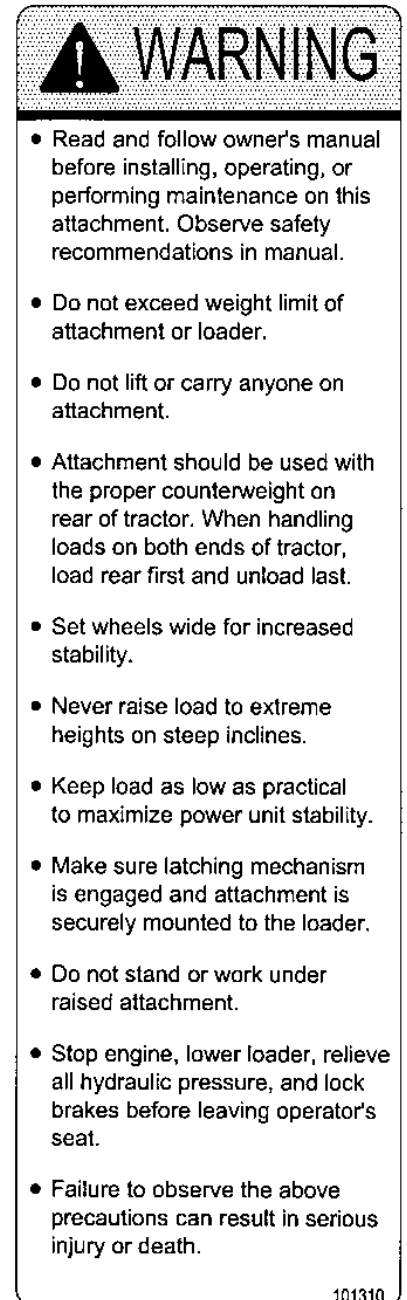

Above Safety Sign ONLY for  
Models JDPF-5442 & JDPF-5448

# INSTRUCTIONS

## TRACTOR AND LOADER/SKID STEER REQUIREMENTS AND PREPARATION

The required size of the tractor and front loader or skid steer will be determined by the weight of the load to be handled.

Always use a tractor and front loader or skid steer large enough to safely handle the load.

Check your tractor and front loader or skid steer to make sure they are in good working condition. Check all frame mounting bolts to make sure they are tight.

Loaders that attach to the tractor frame rails should have a cross-tie installed for stability.

Check the hydraulic system. Be sure the hydraulic oil and filter have been serviced according to the manufacturer's recommendations.

Be sure tires and rims are in good condition. Inflate tires to the proper recommended air pressure.

When lifting loads with a tractor front loader, it is always best to have a heavy implement or weight box connected to the rear 3 pt. hitch.

The load rating of all pallet forks is figured with the load 24" in front of the fork lift frame and evenly distributed between the two fork tines.

**NEVER** put load at the ends of the fork tines – the lift capacity at the ends of the forks is only about 1/3 of the total lift capacity.



### WARNING

■ Power unit must be equipped with ROPS or ROPS cab and seat belt. Keep seat belt securely fastened. Falling off power unit can result in death from being run over or crushed. Keep foldable ROPS systems in "locked up" position at all times.

■ A heavy load can cause instability in driving a power unit. Make sure the rear of the tractor is properly counter-balanced with weights. Always drive slowly – especially around turns. An unstable unit could steer badly and possibly tip over, causing injury or death.

■ Do not exceed the maximum recommended weight listed for the pallet fork. Damage to the equipment or serious personal injury could result.

The operator is responsible for the safe operation of this equipment. The operator must be properly trained. Operators should be familiar with the power unit, loader and loader attachment, and all safety practices before starting operation. Read the safety rules and safety signs on pages 3-11.

**NOTE: Loose items such as logs can slide sideways, thus putting all their weight on one fork. This can bend forks.**

## WARRANTY DOES NOT COVER BENT FORKS.

## PALLET FORK LOAD RATING

<u>MODEL</u>	<u>CAPACITY</u>	<u>FORK LENGTH</u>
PF-448	4,000#	48"
SSPF-3748	4,000#	48"
SSPF-3755	5,500#	48"
SSPF-442	4,000#	42"
SSPF-448	4,000#	48"
SSPF-5548	5,500#	48"
GLPF-442	4,000#	42"
GLPF-448	4,000#	48"
GLPF-5548	5,500#	48"
JDPF-5442	4,000#	42"
JDPF-5448	4,000#	48"
JDPF-6748	5,500#	48"
JDPF-H48048	7,500#	48"
JDPF-H48060	7,500#	60"

The JDPF-6748 and the units above that have Class II rail mounted forks. The JDPF-H48048 and JDPF-H48060 models have Class 3A forks. The load rating for all units is with the load halfway in front of the pallet fork frames (ie - 24" on 48" forks).

# INSTRUCTIONS (continued)

For first time installation, read the instructions for mounting your pallet fork attachment on your front loader or skid steer. (See pages 13-16.)

Remove the bucket from your front end loader. Check your loader to make sure it is in good working order.

## FORK TINE INSTALLATION

With loader arms lowered and completely rolled back, shut down the power unit following the safety shutdown procedure for your unit. Ensure that the locking assembly on the tine is in the unlocked (UP) position. Place the top of the fork on the top rail in the middle of the frame and then rotate down. Slide the fork to the side to seat it on the frame and, using the locking assembly that is on your tine, lock in place. Install the following tine(s) in the same fashion. Make sure the locking assembly has been set into a notch on the top rail and therefore securing the tine to the frame.

**NOTE:** Smearing a light coat of grease on the main frame rails will make adjusting the fork width easier.

**IMPORTANT: Keep forklift tines adjusted to maximum width for better load stability.**

## MODEL PF-448

The Universal model PF-448 Pallet Fork attachment is designed to fit most double-cylinder front end loaders with a load-arm center distance of 52 inches or less. Optional brackets are available to fit both pin-on and some popular quick coupler front-end loaders. Brackets must be ordered with the pallet fork attachment to mount on your loader.

The Universal Pallet Fork can also be used on the rear 3 pt. Cat. II hitch with pin-on brackets and the Optional #831815 Toplink Bracket.

With the optional #830358 Bushing Kit, a Cat. II Quick Hitch may be used. (Pin-on brackets and topline bracket required.)

The model PF-448 with 48" solid pallet forks can handle loads up to 4,000 lbs. Load ratings are figured with the load about 24" in front of the fork lift frame and evenly distributed between the two fork tines.

Install the two backstop weldments on the top crossbar (see page 21).

## ASSEMBLY – TRACTOR LOADERS PIN ON ATTACHMENT

Preview the assembly instructions and the exploded views of the pallet fork in your operator's manual and become familiar as to how the parts or assemblies go together. For model PF-448, see page 21.

Assemble the two lift brackets on the main frame with the  $\frac{5}{8}$ " x 3" I.D. U-bolts. Leave the U-bolts loose.

**NOTE:** The optional lift channel brackets are supplied with 1" diameter pins to fit your loader. If your loader requires  $1\frac{1}{8}$ " pins, it will be necessary for the hole diameter in the channel brackets to be drilled out to  $1\frac{5}{32}$ " (1.156") and ask your dealer to order  $1\frac{1}{8}$ " diameter pins. The  $1\frac{1}{8}$ " pins are part #830318. Be sure to indicate if two or four  $1\frac{1}{8}$ " pins are required.

If your loader requires  $1\frac{1}{4}$ " diameter pins, please ask your dealer to order adapter bushings (part #830319). Be sure to indicate how many adapter bushings are required.

**NOTE:** The Ford (New Holland) models 7109, 7209, 7210, 7309, 7310 and 7410 Pin Type Loaders require special brackets. Also, Rhino (Alamo) models 2410 and 2491. Order #830330 bracket kit.

**NOTE:** For loaders that require brackets that provide additional roll back, order #830335 (1" pins).

Connect the above assembly to the loader arms using the bottom hole in the channel and attach the upper control cylinder to the top hole in the lift channels. Center the main frame (side to side) with your loader arms and tighten the four (4)  $\frac{5}{8}$ " x 3" U-Bolts.

The lower hole positions in the lift channels can be used to obtain more angle movement. However, if the frame becomes too parallel with the loader lift arms, the loader may not have enough power (mechanical advantage) to bring the frame back.

**NOTE:** Generally, it is not recommended to have the tilt cylinders located any closer than 10-12 inches to the main loader lift arms. **Check the spacing of mounting pins on your loader bucket and use this as a guide.**

**NOTE:** If tilt cylinders are located too close to the loader arms, they may go "over center" when fully extended. If this happens, damage may occur to the cylinders and/or mounting brackets.

# INSTRUCTIONS (continued)

## **MODEL PF-448 ASSEMBLY – QUICK ATTACH**

If your tractor loader has a bucket Quick Attach feature, check with your dealer on the availability of adapter brackets for your brand and model loader.

Measure the width of the front adapter on your loader and locate the Quick Attach brackets on the main frame. Locate these brackets so the main frame will be centered on your loader.

Tighten the U-bolts that connect the brackets to the main frame.

Parts drawing for the PF-448 is on page 21.

Install the two backstop weldments on the top crossbar.

## **MODELS SSPF-3748, SSPF-3755, SSPF-442/448 & SSPF-5548**

The Skid Steer Pallet Fork Models SSPF-3748, SSPF-3755, SSPF-442/448 and SSPF-5548 are designed for skid steer power units or tractor loaders having the universal bucket quick attach system.

The Models SSPF-442 and SSPF-448 pallet forks can handle loads up to 4,000 lbs. The Models SSPF-5548 and SSPF-3755 are rated for loads up to 5,500 lbs. These models are for the standard size skid steer units and tractors above 40 hp. Load ratings are figured at half the length of the tines.

Make sure latch pins engage slots to lock the frame in place.

Connection instructions are on page 15.

## **MODELS GLPF-442/448/5548 ATTACHMENT TO PRIME MOVER**

The Models GLPF-442, GLPF-448, and GLPF-5548 are specifically designed for tractor front loaders with the Euro or Global bucket quick-change system.

The Models GLPF-442/448 have a load rating of 4,000 lbs.

The Model GLPF-5548 has a load rating of 5,500 lbs.

Connection instructions are on page 16.

## **MODELS JDPF- 5442/5448 ATTACHMENT TO PRIME MOVER**

The Pallet Fork Models JDPF-5442 and JDPF-5448 are specifically designed for John Deere 400 and 500 series loaders. They are rated for loads up to 4,000 lbs.

Connections instructions are on page 17.

## **MODEL JDPF-6748 ATTACHMENT TO PRIME MOVER**

The Model JDPF-6748 pallet fork is specifically designed for John Deere 600 and 700 series loaders with quick-change latches. It has a load rating of up to 5,500 lbs.

Connections instructions are on page 18.

## **MODELS JDPF-H48048 & H48060**

These two models are designed for the John Deere H480 loader. The Model JDPF-H48048 has 48" long fork tines and the Model JDPF-H48060 has 60" long fork tines. Both models are rated at 7,500 lb. with the load 24" in front of the fork frame and evenly distributed on the two fork tines.

The connection to the loader is the Global Series II.

The forks are 1.75" x 4.75" width Class III solid type forks that are sliding adjustable on a 50" wide carriage.

Connection instructions for the JDPF-H480 Models are similar to the ones for the standard Euro or Global units. (See page 16.)

# OBEY ALL SAFETY WARNINGS!

# INSTRUCTIONS (continued)

## MODELS SSPF-442/448/3748/3755 ATTACHMENT TO PRIME MOVER

### **WARNING**

Improper attachment of the Pallet Fork could result in injury or death. Do not operate this product until you have positive indication that the attachment is securely mounted.

1. Position the attachment on a level surface.
2. The quick attach coupler handles should be in the unlocked position with lock pins retracted, Figure 2.

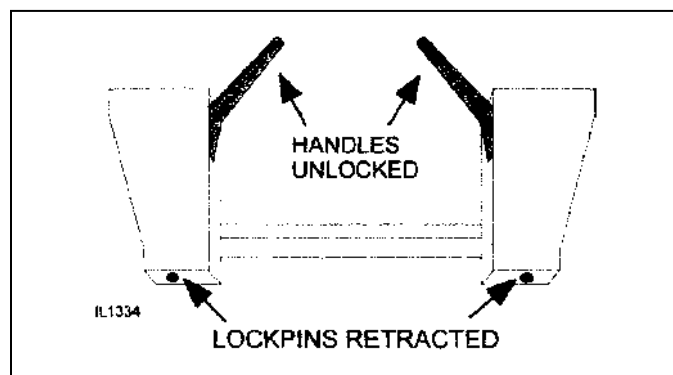

**Figure 2.** Quick Attach Coupler Handles - Unlocked

3. Enter the prime mover. Fasten seatbelt, start engine. Disengage the parking brake.
4. Follow the attaching procedure in the prime mover owner's manual. Align the attachment mechanism with the mounting on the pallet fork, attach to the prime mover on loader.
5. Engage the parking brake and shut down the prime mover. Be sure to relieve pressure to the auxiliary hydraulic lines.
6. Unfasten safety restraints and exit the prime mover.
7. Engage the latching mechanism to secure attachment to loader. The lockpins must be completely extended and secured into the retaining slots.
8. Re-enter the prime mover. Fasten seatbelt and re-start engine.

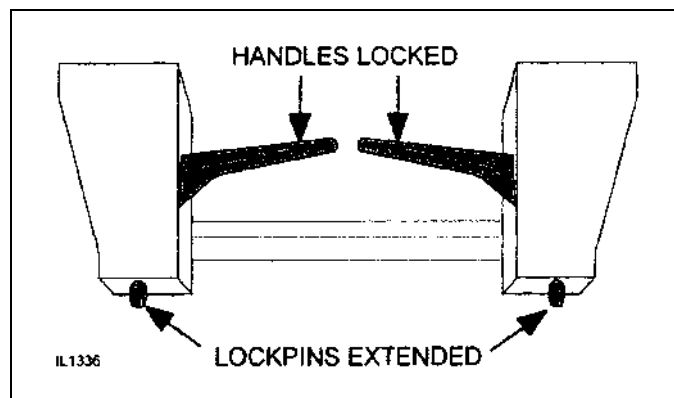

**Figure 3.** Attachment Coupler Handles - Locked

### **WARNING**

Attachment coupler handles must always be rotated to **LOCK POSITION** to prevent coupler latch from disengaging and attachment from falling off.

9. Carefully raise the loader and cycle the rollback/tilt cylinders to check clearances and to ensure that the attachment is securely mounted.

## REMOVING THE PALLET FORK

1. If possible, find a level solid location to place the attachment. This makes it easier to disconnect and re-connect later on.
2. Lower the attachment to the ground.
3. Engage the parking brake and shut down the prime mover. Be sure to relieve pressure to the auxiliary hydraulic lines.
4. Unfasten safety restraints and exit prime mover.
5. Disengage attachment-locking mechanism (mechanical type).
6. Enter prime mover, fasten safety restraints and start the prime mover.
7. Disengage attachment-locking mechanism (hydraulic type).
8. Disengage the parking brake, and back away from the attachment.



# INSTRUCTIONS (continued)

## **MODELS GLPF-442/448/5548 ATTACHMENT TO PRIME MOVER**

The Models GLPF-442, GLPF-448, and GLPF-5548 are specifically designed for tractor front loaders with the Euro or Global bucket quick-change system.

The Models GLPF-442/448 have a load rating of 4,000 lbs.

The Model GLPF-5548 has a load rating of 5,500 lbs.

The instructions for the JDPF-H480 Models are similar to the Euro/Global ones.

### **ATTACHING**

1. To prepare the loader for attachment, pull and rotate handle to open latch (A).
2. Extend attachment cylinders to angle attaching brackets forward.
3. Drive forward, adjusting loader height and position until the bar (B) is under hooks (C) and tabs (D) are on the center side of the hooks.

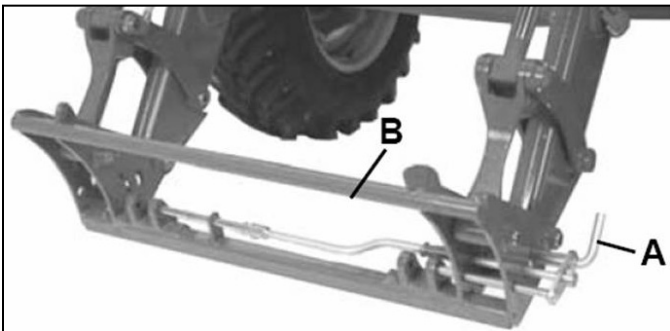

**NOTE:** Latch automatically closes on some global carrier. Always check latch pins.

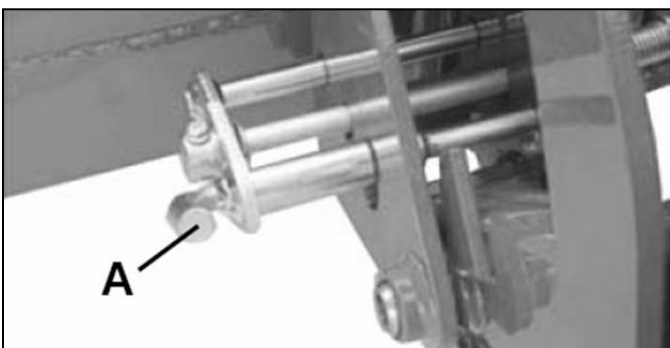

4. Raise loader and retract tilt cylinders until latch closes.
5. Lower attachment and shut off engine. Installation is now complete.

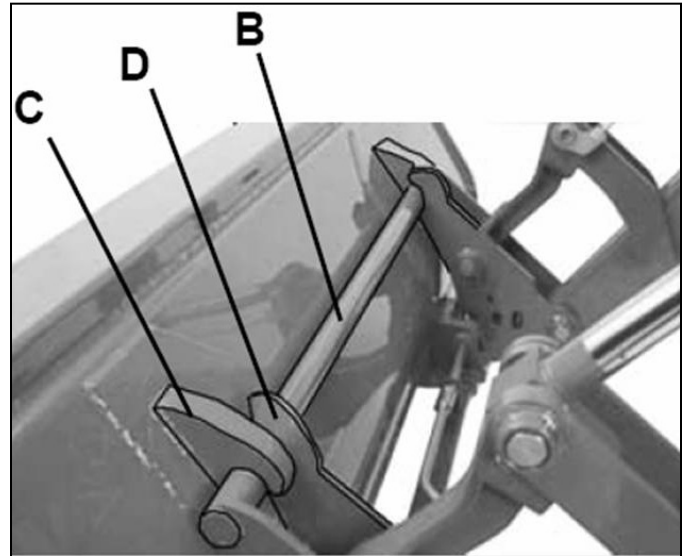

**CAUTION!**



**ALWAYS CHECK LATCH PINS  
BEFORE TILTING OR OPERATING  
ANY ATTACHMENT.**

### **DETACHING**

1. Lower pallet fork to ground. Place the transmission in PARK and shut off engine and remove key.
2. Pull and rotate handle to open latch (A).
3. Start tractor and lower attachment to ground. Slowly extend bucket tilt cylinders until loader clears the latch plate. Lower loader until bar clears the hooks.
4. Drive tractor in reverse until loader is clear of the attachment.

**OBEY ALL SAFETY WARNINGS!**

# INSTRUCTIONS (continued)

## **MODELS JDPF-5442/5448 ATTACHMENT TO PRIME MOVER**

The Pallet Fork Models JDPF-5442 and JDPF-5448 are specifically designed for John Deere 400 and 500 series loaders. They are rated for loads up to 4,000 lbs.

**NOTE: Procedure is the same for all attachments. Bucket attachment shown.**

### **ATTACHING**

1. Extend bucket tilt cylinders to angle attaching brackets forward.

**NOTE: Angle must be greater than that of the brackets on the rear of the pallet fork.**

2. Drive forward, adjusting loader height and position until the top of the loader bracket engages the hooks (C) on the pallet fork.
3. Slowly retract the bucket tilt cylinders and raise the loader so the lower lock pins (F) engage the hole in the holder strap (E).
4. Continue to retract the tilt cylinders and raise the loader until the main frame of the pallet fork is vertical.
5. Engage tractor parking brake and/or place transmission in PARK. Shut off tractor engine and remove key.
6. Install the quick-lock-pin (A) into the pins (F) on each side of the pallet fork.

Installation is now complete.

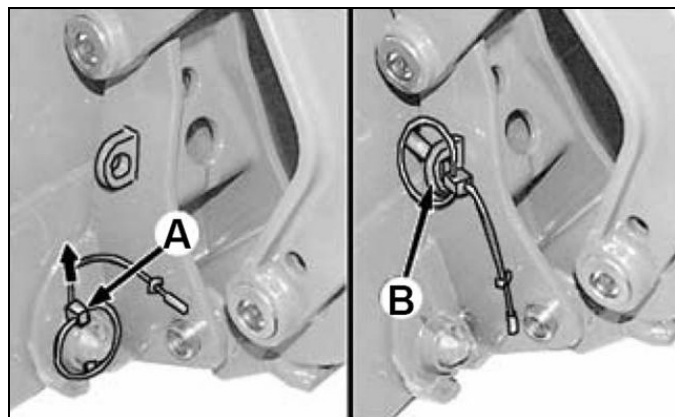
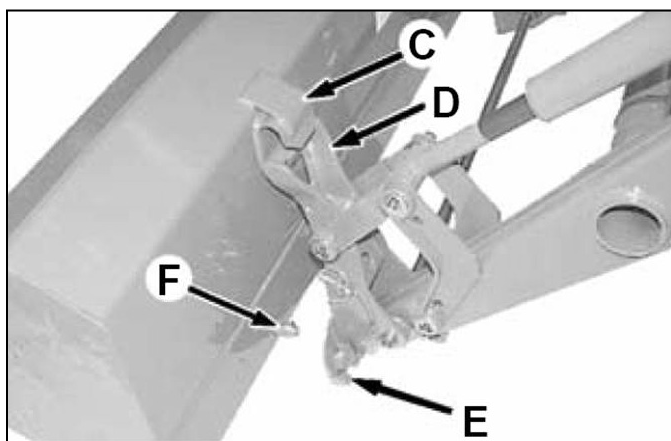

**NOTE: On attachments with two pins (F), the 400 series loaders will utilize the upper pin and the 500 series loader will utilize the lower pin.**

### **! WARNING**

**Always install the quick lock pins on the John Deere 400, and 500 series loaders. Failure to install the lock pins may cause injury or death caused by falling attachment.**

### **DETACHING**

1. Engage tractor parking brake and/or place transmission in PARK. Shut off tractor engine and remove key.
2. Remove the quick lock-pin (A) from each side of attachment. Store pins in storage position (B).
3. Start engine and lower the pallet fork to the ground. Extend bucket tilt cylinders until pin (F) releases from holder strap (E) on each side of attachment. Lower the loader until holder brackets are free from the hooks. Back tractor away from attachment.
4. Set parking brake and/or place transmission in PARK. Shut off engine and remove key.

# INSTRUCTIONS (continued)

## **MODEL JDPF-6748 ATTACHMENT TO PRIME MOVER**

The Model JDPF-6748 Pallet Fork is specifically designed for John Deere 600 and 700 series loaders with quik-change latches. It has a load rating of up to 5,500 lbs.

**NOTE: Procedure is the same for all attachments. Bucket attachment shown.**

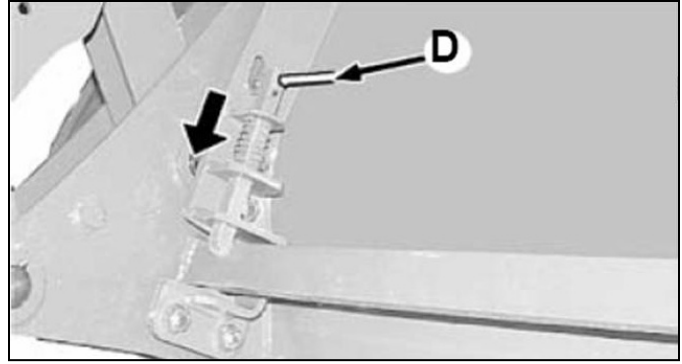

**700 SERIES BOLT-ON LATCH SHOWN**

### **ATTACHING**

1. Extend bucket tilt cylinders to angle attaching brackets forward.

**NOTE: Angle must be greater than that of the brackets on the rear of the pallet fork.**

2. 600/700 – Drive forward, adjusting loader height and position until the top of the bracket is aligned with the pins (A).
3. Raise loader to engage hooks and retract attachment cylinders quickly.
4. 600/700 – Raise loader until you can check that pins (D) on both sides have fully dropped.
5. Lower attachment, shut off engine and remove key.

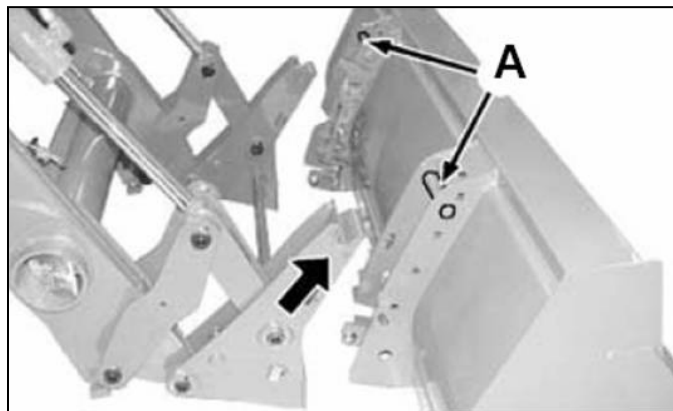

**700 SERIES**

### **CAUTION!**



**ALWAYS CHECK LATCH PINS  
BEFORE TILTING OR OPERATING  
ANY ATTACHMENT.**

### **DETACHING**

1. Lower pallet fork to ground. Place the transmission in PARK and shut off engine and remove key.
2. Lift and rotate latches (A) up on both sides of attachment.
3. Start tractor and lower attachment to ground. Slowly extend bucket tilt cylinders until loader brackets clear the latch pin pockets. Lower loader until holder clears the pins.
4. Drive tractor in reverse until loader is clear of the attachment.

## **MODELS JDPF-H48048 & H48060**

These two models are designed for the John Deere H480 loader. The Model JDPF-H48048 has 48" long fork tines and the Model JDPF-H48060 has 60" long fork tines. Both models are rated at 7,500 lb. with the load 24" in front of the fork frame and evenly distributed on the two fork tines.

The connection to the loader is the Global Series II.

The forks are 1.75" x 4.75" width Class III solid type forks that are sliding adjustable on a 50" wide carriage.

Connection instructions for the JDPF-H480 Models are similar to the ones for the standard Euro or Global units. (See page 16.)

# OPERATING INSTRUCTIONS

## OPERATION

Safety is a primary concern in the design and manufacture of our products. Unfortunately, our efforts to provide safe equipment can be wiped out by an operator's single careless act.

In addition to the design and configuration of equipment, hazard control and accident prevention are dependent upon the awareness, concern, judgement, and proper training of personnel involved in the operation, transport, maintenance and storage of equipment.

It has been said "The best safety device is an informed, careful operator." We ask you to be that kind of operator.

The operator is responsible for the safe operation of this equipment. The operator must be properly trained. Operators should be familiar with the equipment, the tractor, and all safety practices before starting operation. Read the safety rules and safety decals on pages 3 through page 11.



## WARNING

■ Do not operate this product until you have positive indication that this attachment is securely mounted to the loader. Failure to install lock pins or have the latching mechanism engaged could result in injury or death.

■ Power unit must be equipped with ROPS or ROPS cab and seat belt. Keep seat belt securely fastened. Falling off power unit can result in death from being run over or crushed. Keep foldable ROPS systems in "locked up" position at all times.

■ Pallet Forks are NOT to be used for large round bales, as this would create a hazardous condition.



## DANGER

Beware of low electrical wires when loader is raised. Serious injury or death can result if contact is made.

Do not leave the operator's seat if any part of the power unit, loader or attachment contacts electric lines.



## WARNING

■ Rear ballast is required to ensure 25% of gross vehicle weight is transferred to the rear axle. Attachment and load must be included as weight. Adequate rear weights are required to counterbalance maximum loader capacity and safe loader operation. Weight can be added as rear tire liquid, rear wheel weights, rear axle weights and/or three point hitch mounted ballast or implement. Ballasting will vary with tractor and loader attachment. Refer to the Tractor manual for recommended ballasting.

■ Never allow children or untrained persons to operate equipment.

■ Keep bystanders away from equipment.

■ Never allow riders on power unit or attachment.

Be sure tractor or skid steer is properly counterbalanced with weights before attempting to lift any load.

Make sure fork latch is properly engaged.

Using the bucket tilt cylinders, adjust the angle of the fork tines so they are parallel with the ground.

Adjust height of fork tines to enter the pallet to be handled. Always keep the load or pallet as close to the forklift main frame as possible.

Make sure weight of load is centered between the forks.

Make sure all operators have read the Owner's Manual and are familiar with the instructions and the safety rules of operation.



## CAUTION

■ Avoid carrying loose or shiftable loads. Falling items could cause injury.

■ Beware of lift clearance when raising loader to maximum height.

■ Always stop the power unit, set brake, shut off engine, remove key, and lower loader to ground before attempting to service. Never leave equipment unattended with engine running.

# OPERATING INSTRUCTIONS (continued)

## OPERATION (continued)

---



### WARNING

Operate up and down slopes with the heavy end of the machine uphill. Carrying a load with the pallet fork attachment will make the front end heavy.

When going up or down hill, the machine could overturn if the heavy end is toward the downhill side. Someone may be pinned or seriously injured if the machine overturns.



### OPERATE LOADER SAFELY

---

- Adjust the spacing of the forks so they engage the pallet or load at its maximum width and then approach the load in such a fashion that the weight will be centered between the fork tines. The heaviest side should be closest to the fork frame and not near the tips of the fork tines.
- Before lifting make certain the fork tines are completely under the load and level. (Fork length should be at least two-thirds of load length).
- Lift the load slightly to make sure the load is stable. If load appears unstable, lower and reposition the tines to achieve full stability.
- Raise the load to the MINIMUM height required for the terrain.
- During transportation; keep the fork tines level, gradually accelerate and brake, slow down before turning and avoid any obstacles, bumps or holes. Check load frequently to ensure stability.
- Start lifting slowing and smoothly. Lift speeds can be slightly increased once the load has started moving and appears to be stable.
- If the load starts to lean or move, lower to the ground and reposition.
- Lower the load gently until the weight of the load is securely resting on the landing point and the forks are free to be retracted from under the load.
- Make sure weight of load is centered between the forks.

**IMPORTANT: Keep forklift tines adjusted to maximum width for better load stability.**

## TRANSPORTING

---



### CAUTION

When traveling on public roads, whether at night or during the day, use accessory light and devices for adequate warnings to operators of other vehicles. Comply with all federal, state and local laws.

Allow for additional length of loader and attachment on power unit while turning.

Check visibility. If visibility is impaired, reduce speed or consider other means of transport.

Read all the safety warnings in the front of this manual and in the manual of power unit.



### WARNING

Transport the loaded pallet fork at a slow speed and with the loader at the lowest transport position to avoid tipping or upsetting, which could result in serious injury or death.

## MAINTENANCE & STORAGE

---

Replace any worn or damaged parts immediately. Do not use attachment with any damaged parts.

Smearing a light coat of grease on the main frame rails will make adjusting the fork width easier.



### WARNING

■ Always stop the tractor or skid steer, set brake, shut off engine, remove key, and lower loader to ground before attempting to service. Never leave equipment unattended with engine running.

■ Do not work under a raised loader unless it is securely blocked or held in position. Do not depend on the hydraulic system to hold loader and attachment in place.

■ Keep all persons away from operator control area while performing adjustments, service, or maintenance.

Storage location should be level and solid to make hitching and unhitching easy. Store in a clean, dry location away from children and livestock.

## MODEL PF-448 PARTS LIST

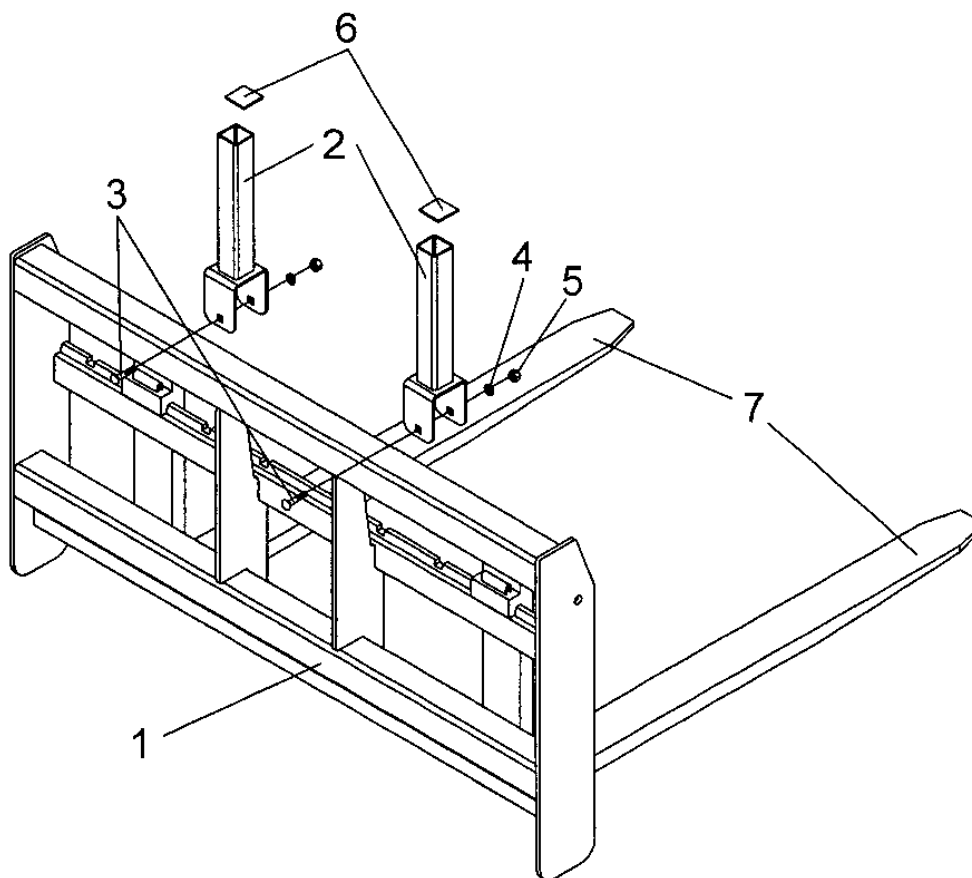

Ref. No.	Part No.	Description	No. Req'd.
1	831831	Frame Weldment (PF-448)	1
2	831835	Backstop Weldment (PF-448)	2
3	2503217	Bolt, Carriage 1/2"-13NC x 4.50" G2	2
4	2502002	Washer, 1/2" Spring Lock	2
5	2500003	Nut, Hex 1/2"-13NC	2
6	2504309	Cap, Plastic (2 x 2)	2
7	831375	Pallet Fork, 48" (4,000# / Pair Capacity)	2
N/S	101037	Safety Sign, Caution (Capacity)	1
N/S	101310	Safety Sign, Warning (Owner's Manual)	1
N/S	101314	Safety Sign, Caution (Fork Limit)	1
N/S	101317	Safety Sign, Warning (Falling Objects)	1
N/S	2504274	Fork Latch Repair Kit	

# MODELS SSPF-442, SSPF-448 & SSPF-5548 PARTS LIST

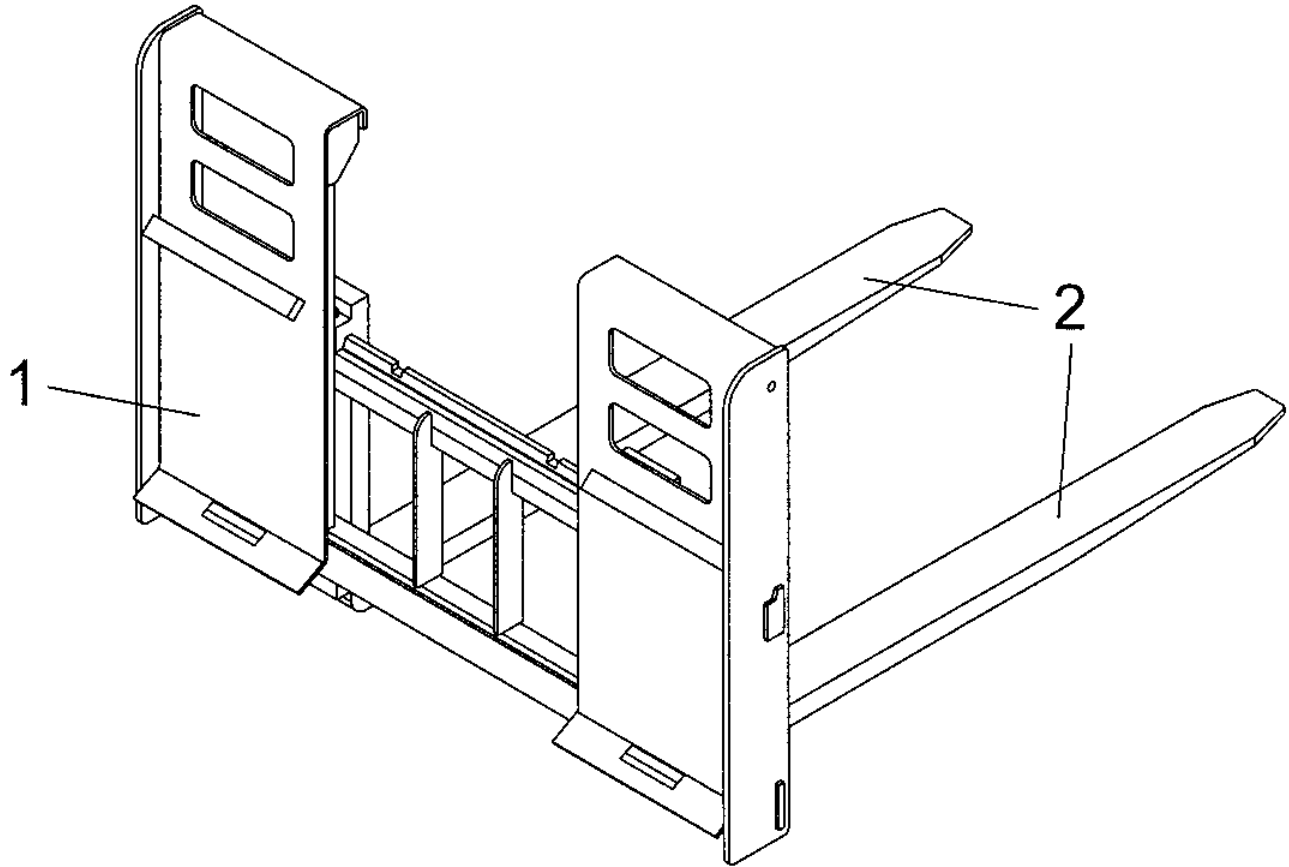

Ref. No.	Part No.	Description	No. Req'd.
1	832401	Frame Weldment, SS Pallet Fork	1
2	831365	Pallet Fork, 42" (442) (4,000# / Pair Capacity)	2
	831375	Pallet Fork, 48" (448) (4,000# / Pair Capacity)	2
	832470	Pallet Fork, 48" (5548) (5,500# / Pair Capacity)	2
N/S	101037	Safety Sign, Caution (Capacity)	2
N/S	101310	Safety Sign, Warning (Owner's Manual)	1
N/S	101314	Safety Sign, Caution (Fork Limit)	1
N/S	101317	Safety Sign, Warning (Falling Objects)	1
N/S	2504274	Fork Latch Repair Kit	

# MODELS SSPF-3748 & SSPF-3755 PARTS LIST

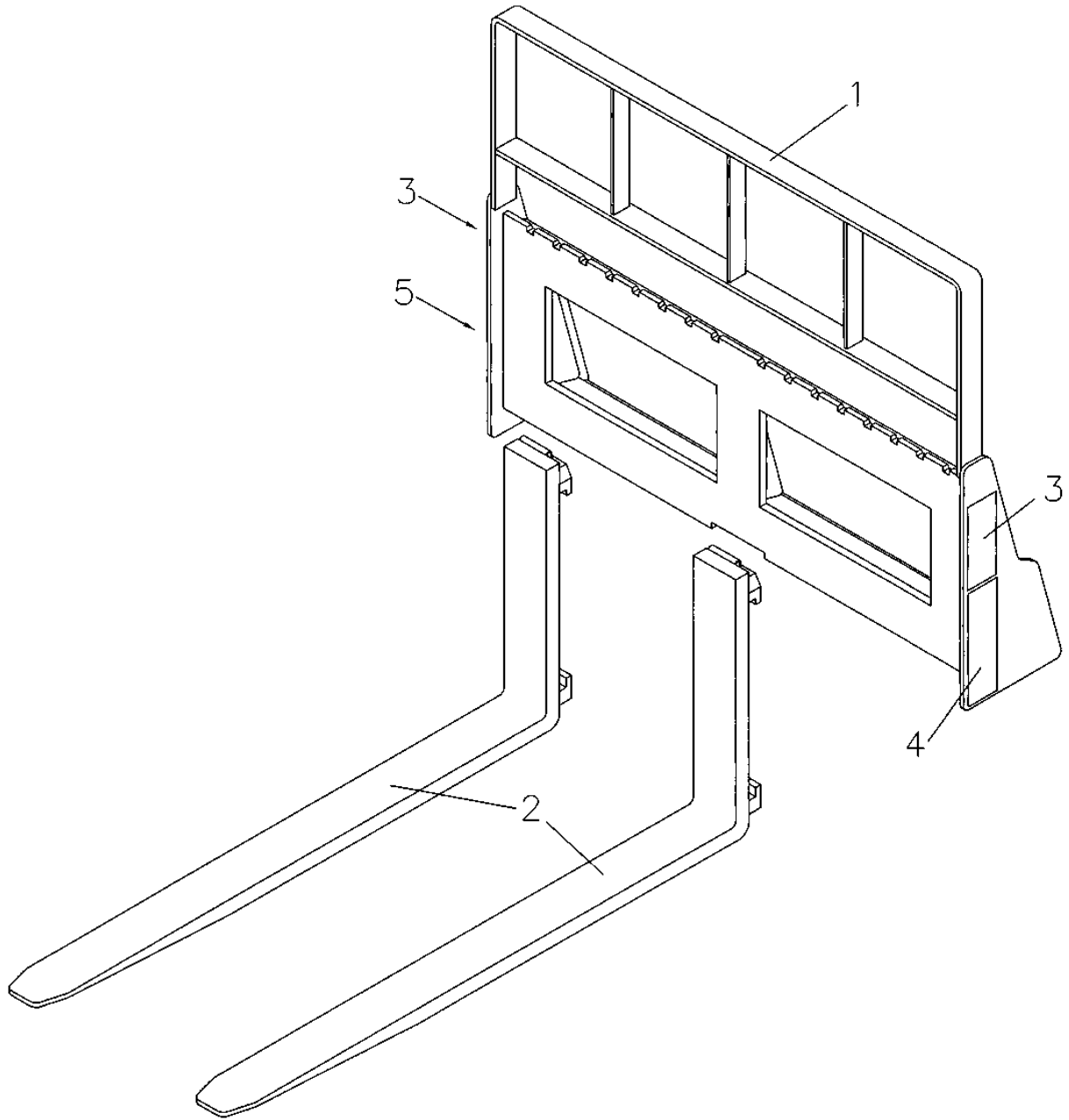

Ref. No.	Part No.	Description	No. Req'd.
1	831371	Main Frame Weldment (SSPF-3748 & SSPF-3755)	1
2	831375	1 3/8" x 48" Fork (SSPF-3748) 4000# / Pair	2
	832470	1 1/2" x 48" Fork (SSPF-3755) 5500# / Pair	2
3	101037	Safety Sign - Caution (Capacity)	2
4	101310	Safety Sign - Warning (Pallet Forks)	1
5	101314	Safety Sign - Caution (Fork Limit)	1
N/S	2504274	Fork Latch Repair Kit	



# MODELS GLPF-442, GLPF-448 & GLPF-5448 PARTS LIST

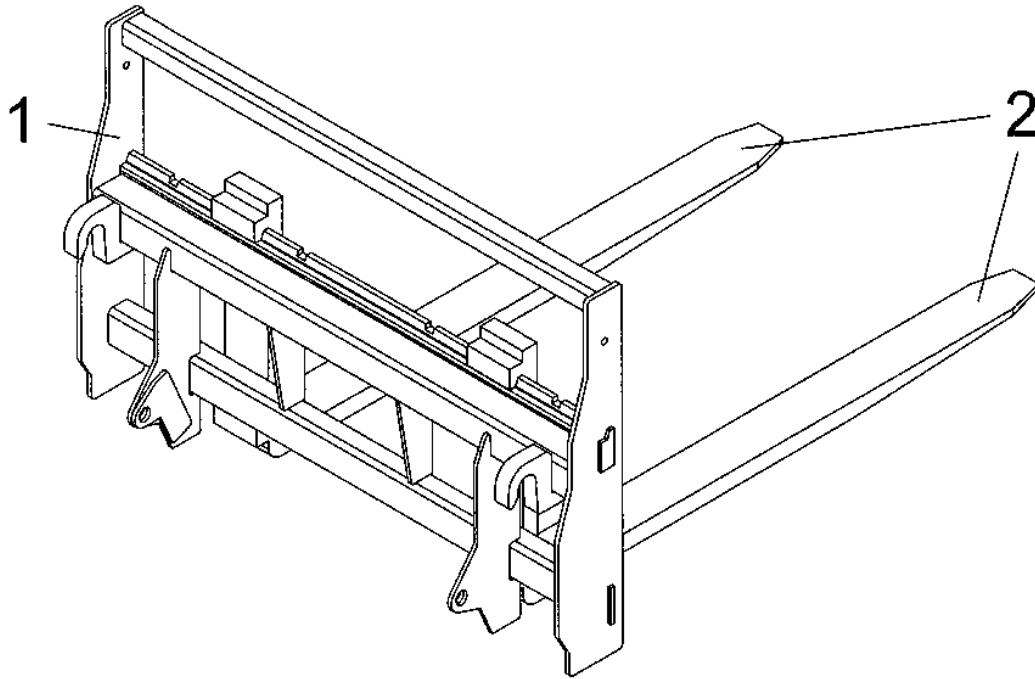

Ref. No.	Part No.	Description	No. Req'd.
1	832476	Frame Weldment, Pallet Fork	1
2	831365	Pallet Fork, 42" (442) 4000# Capacity	2
	831375	Pallet Fork, 48" (448) 4000# Capacity	2
	832470	Pallet Fork, 48" (5548) 5500# Capacity	2
N/S	101037	Safety Sign, Caution (Capacity)	1
N/S	101310	Safety Sign, Warning (Owner's Manual)	1
N/S	2504274	Fork Latch Repair Kit	

## MODELS JDPF-5442 & JDPF-5448 PARTS LIST

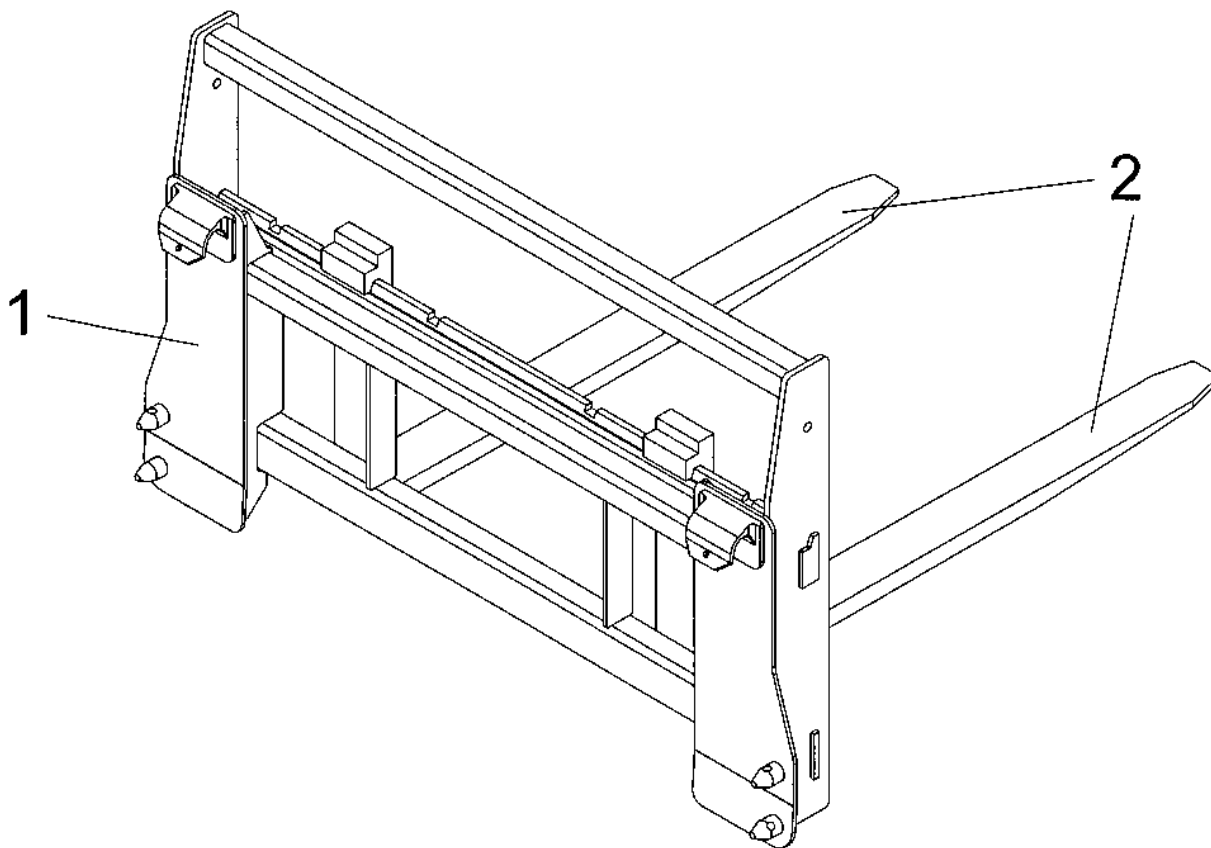

Ref. No.	Part No.	Description	No. Req'd.
1	832436	Frame Weldment, Pallet Fork	1
2	831365	Pallet Fork, 42" (5442) (4,000# / Pair Capacity)	2
	831375	Pallet Fork, 48" (5448) (4,000# / Pair Capacity)	2
N/S	101037	Safety Sign, Caution (Capacity)	1
N/S	101310	Safety Sign, Warning (Owner's Manual)	1
N/S	101296	Safety Sign, Warning (Lock Pins)	1
N/S	101317	Safety Sign, Warning (Falling Objects)	1
N/S	2504274	Fork Latch Repair Kit	

## MODEL JDPF-6748 PARTS LIST

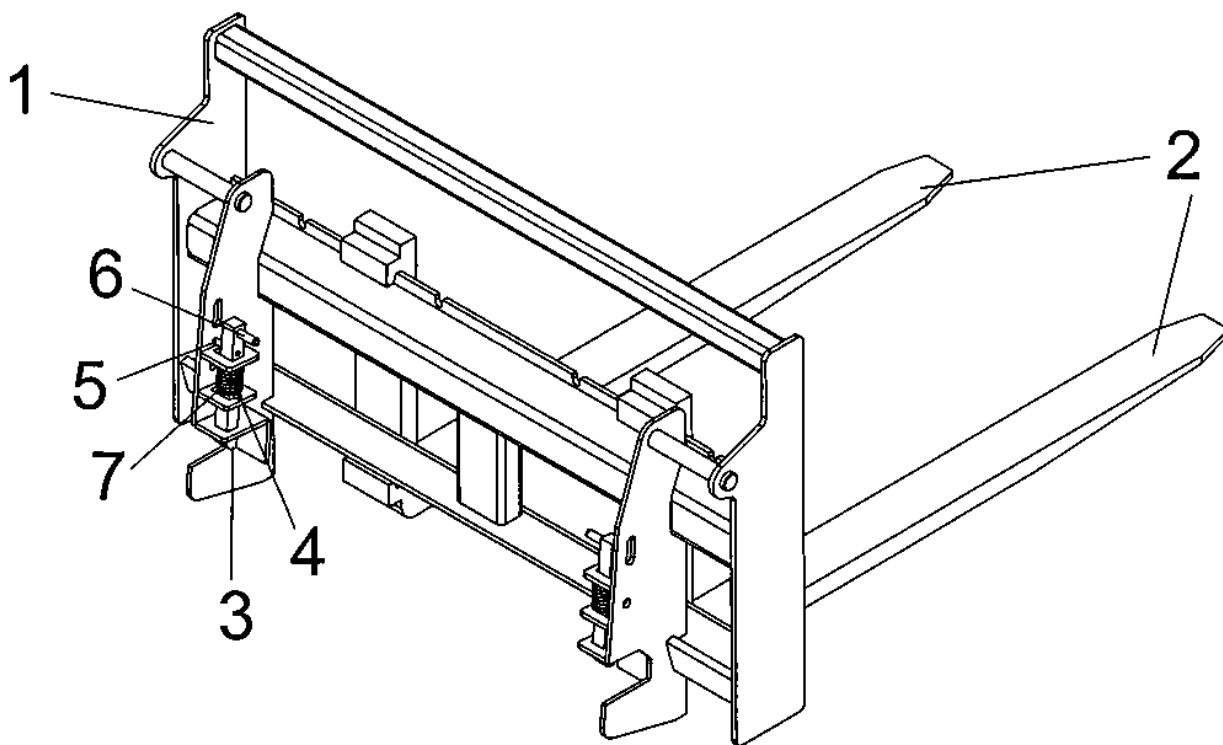

Ref. No.	Part No.	Description	No. Req'd.
1	832441	Frame Weldment, Pallet Fork	1
2	832470	Pallet Fork, 48" (4,000# / Pair Capacity)	2
3	831872	Lock Bar	2
4	2504070	Roll Pin 5/16" x 2"	2
5	2504224	Roll Pin 3/8" x 2"	2
6	2504195	Roll Pin 1/2" x 2 1/2"	2
7	2504223	Spring, Lock Bar	2
N/S	101037	Safety Sign, Caution (Capacity)	1
N/S	101310	Safety Sign, Warning (Owner's Manual)	1
N/S	101317	Safety Sign, Warning (Falling Objects)	1
N/S	2504274	Fork Latch Repair Kit	

# MODELS JDPF-H48048 & JDPF-H48060 PARTS LIST

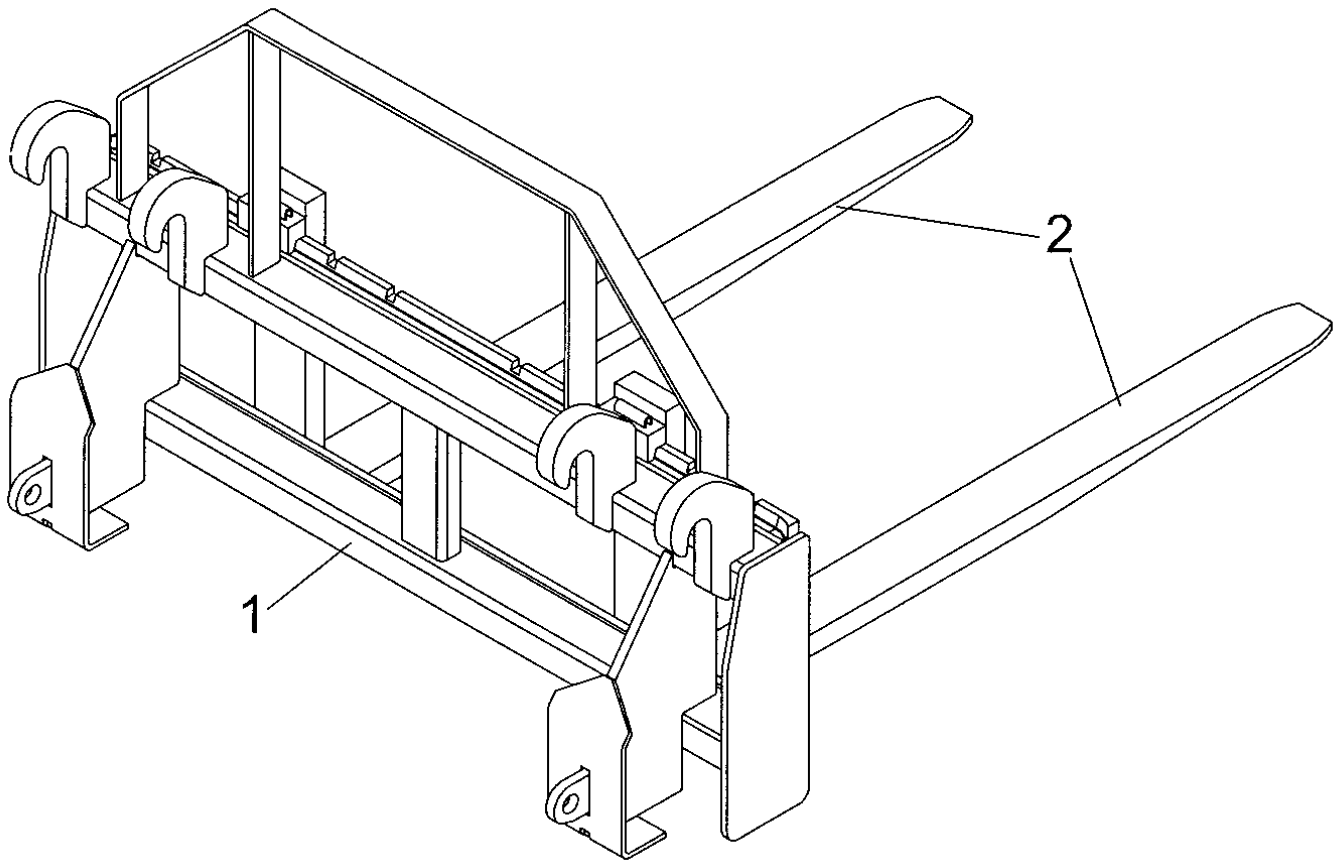

Ref. No.	Part No.	Description	No. Req'd.
1	834131	Frame Weldment, Pallet Fork	1
2	834141	48" Fork, Class 3A (7,500# / Pair Capacity)	2
	834142	60" Fork, Class 3A (7,500# / Pair Capacity)	2
N/S	101026	Safety Sign - Caution (Read Instructions)	1
N/S	101034	Safety Sign - Caution (Heavy Load)	1
N/S	101037	Safety Sign - Caution (Observe Capacity)	1
N/S	101316	Safety Sign - Caution (Rated Capacity)	1
N/S	101317	Safety Sign - Warning (Falling Objects)	1



# SAFETY REQUIREMENTS

AVOID ACCIDENTS BY FOLLOWING ALL OF THE SAFETY REQUIREMENTS LISTED BELOW.

- Machinery should be operated only by those who are responsible and are authorized to do so.
- Stop the engine, lower all equipment, lock the brakes, and remove the ignition key before dismounting from the tractor.
- Never stand between tractor and implement while tractor is being backed to hitch.
- Loose fitting clothing should not be worn, to avoid catching on various parts.
- Detach implement in area where children normally do not play.
- When performing adjustments or maintenance on an implement, first lower it to the ground or block it securely at a workable height.
- Only a qualified operator should be permitted on tractor when in operation; no riders allowed.
- Make certain everyone is in the clear before starting tractor or raising or lowering equipment.
- Operate the tractor and implement only while seated in the driver's seat.
- Reduce speed when transporting mounted implements to avoid bouncing and momentary loss of steering control.
- A heavy load can cause instability of the tractor. Use extreme care during road travel. Slow down on turns and watch out for bumps. Tractor may need front counterweights to counter-balance the weight of the implement.
- Reduce speed on hillsides or curves so there is no danger of tipping.
- Avoid driving too close to the edge of ditches or creeks.
- Do not transport implement on public roads without reflectors and slow moving vehicle emblem in daylight and with approved warning lights at night and other periods of poor visibility.
- Due to the width of some implements, use extra caution on highways, farm roads, and when approaching gates.
- Always be sure the implement is in the proper position for transport.
- Keep alert and watch the front as well as the rear when working with the implement.

OWNER'S/  
OPERATOR'S  
MANUAL

MODEL NO.'s

PF-448

SSPF-3748

SSPF-3755

SSPF-442

SSPF-448

SSPF-5548

GLPF-442

GLPF-448

GLPF-5548

JDPF-5442

JDPF-5448

JDPF-6748

JDPF-H48048

JDPF-H48060

MARCH 2017

## PALLET FORKS FOR TRACTOR FRONT LOADERS AND SKID STEER UNITS

WHEN ORDERING REPAIR PARTS,  
ALWAYS GIVE THE FOLLOWING INFORMATION:

1. PART NUMBER
2. PART DESCRIPTION
3. MODEL NUMBER
4. NAME OF ITEM

Please work, drive, play, and live each day with care and concern for your safety and that of your family and fellow citizens.

**WORKSAVER, INC.**

P.O. BOX 100 LITCHFIELD, IL 62056-0100 (217) 324-5973

WEB: <http://www.worksaver.com> E-MAIL: [sales@worksaver.com](mailto:sales@worksaver.com)