

OWNER'S/ OPERATOR'S MANUAL

MODEL NO.'s
EB-6-3
EB-7-3

⚠ CAUTION

For Safe Operation
Read Rules And
Instructions Carefully

SINO LEEINGLES, PIDA AYUDA
A AIGUIEN QUE SI LO LEA
PARA QUE LE TRADUZCA LAS
MEDIDAS DE SEGURIDAD.

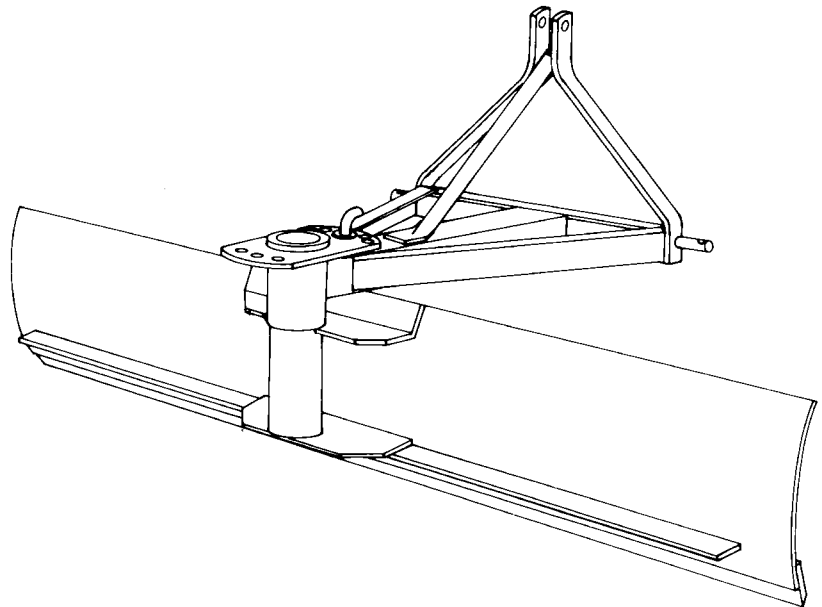

3 Pt. Rear Mounted Blade

**For Cat. I 3 Pt. Hitch Tractors
from 17 to 35 H.P.**

Safety Instructions
Tractor Preparation
Operating Instructions

Assembly & Mounting
Maintenance
Repair Parts

⚠ CAUTION

**THE FOLLOWING SAFETY PRECAUTIONS SHOULD BE THOROUGHLY UNDERSTOOD
BEFORE ATTEMPTING TO BEGIN ASSEMBLING THIS MACHINE**

1. Select an area for assembly that is clean and free of any debris which might cause persons working on the assembly to trip.
2. Do not lift heavy parts or assemblies. Use crane, jack, tackle, fork trucks or other mechanical devices.
3. Preview the assembly instructions in your operator's manual before proceeding further.
4. If the assembly instructions call for parts or assemblies to be blocked up, use only blocking material that is in good condition and is capable of handling the weight of the assembly to be blocked. Also insure that the blocking material is on a clean, dry surface.
5. Never put hands, or any part of body, under blocked up assemblies if at all possible.
6. After completing assembly, thoroughly inspect the machine to be sure that all nuts, bolts, hydraulic fittings or any other fastened assemblies have been thoroughly tightened.
7. Before operating the machine, thoroughly read the operation section of your operator's manual.
8. Before operating, read the maintenance section of your operator's manual to be sure that any parts requiring lubrication, such as gearboxes, are full, to avoid any possible damage.
9. **Before operating equipment – If you have any questions regarding the proper assembly or operation, contact your dealer or representative.**

To the Owner/Operator/Dealer

All implements with moving parts are potentially hazardous. There is no substitute for a cautious, safe-minded operator who recognizes the potential hazards and follows reasonable safety practices. The manufacturer has designed this implement to be used with all its safety equipment properly attached to minimize the chance of accidents.

BEFORE YOU START!!

**Read the safety messages on the implement and shown in your manual.
Observe the rules of safety and common sense!**



THIS SYMBOL MEANS

- ATTENTION!
- BECOME ALERT!
- YOUR SAFETY IS INVOLVED!

THIS SAFETY ALERT SYMBOL IDENTIFIES IMPORTANT SAFETY WARNING MESSAGES. CAREFULLY READ EACH WARNING MESSAGE THAT FOLLOWS. FAILURE TO UNDERSTAND AND OBEY A SAFETY WARNING, OR RECOGNIZE A SAFETY HAZARD, COULD RESULT IN AN INJURY OR DEATH TO YOU OR OTHERS AROUND YOU. THE OPERATOR IS ULTIMATELY RESPONSIBLE FOR THE SAFETY OF HIMSELF, AS WELL AS OTHERS, IN THE OPERATING AREA OF THE TRACTOR AND ATTACHED EQUIPMENT.

UNDERSTAND SIGNAL WORDS

Note the use of the signal words **DANGER**, **WARNING** and **CAUTION** with the safety messages. The appropriate signal word for each has been selected using the following guidelines:

DANGER: Indicates an imminently hazardous situation that, if not avoided, will result in death or serious injury. This signal word is to be limited to the most extreme situations typically for machine components which, for functional purposes, cannot be guarded.

WARNING: Indicates a potentially hazardous situation that, if not avoided, could result in death or serious injury, and includes hazards that are exposed when guards are removed. It may also be used to alert against unsafe practices.

CAUTION: Indicates a potentially hazardous situation that, if not avoided, may result in minor or moderate injury. It may also be used to alert against unsafe practices.

If you have questions not answered in this manual or require additional copies or the manual is damaged, please contact your dealer or the manufacturer directly.

IMPORTANT SAFETY INFORMATION!















Working with unfamiliar equipment can lead to careless injuries. Read this manual, and the manual for your tractor, before assembly or operating, to acquaint yourself with the machines. It is the implement owner's responsibility, if this machine is used by any person other than yourself, is loaned or rented, to make certain that the operator, prior to operating:

1. Reads and understands the operator's manuals.
2. Is instructed in safe and proper use.















The use of this equipment is subject to certain hazards which cannot be protected against by mechanical means or product design. All operators of this equipment must read and understand this entire manual, paying particular attention to safety and operating instructions, prior to using. If there is something in this manual you do not understand, ask your supervisor, or your dealer, to explain it to you.

SAFETY INSTRUCTIONS (continued)

-  All equipment is potentially hazardous. There is no substitute for a cautious, safe-minded operator who recognizes potential hazards and follows reasonable safety practices.
-  When the use of hand tools is required to perform any part of assembly, installation, adjustment, maintaining, repairing, removal, or moving the implement, be sure the tools used are designed and recommended by the tool manufacturer for that specific task.
-  Personal protection equipment including safety glasses, safety shoes, and gloves are recommended during assembly, installation, operation, adjustment, maintaining, repairing, removal, or moving the rear blade.
-  Always use two people to handle heavy, unwieldy components during assembly, installation, removal, or moving the rear blade.
-  Never place any part of your body where it would be in danger if movement should occur during assembly, installation, operation, maintaining, repairing, removal, or moving the implement.
-  Never place yourself between the tractor and implement while implement is in operation.
-  Do not work under a raised implement unless it is securely blocked or held in position. Do not depend on the tractor hydraulic system to hold the implement in place.
-  A heavy load can cause instability of the tractor. Use extreme care during travel. Slow down on turns and watch out for bumps. The tractor may need front counter-weights to counter-balance the weight of the implement.
-  Never use alcoholic beverages or drugs which can hinder alertness or coordination while operating this equipment. Consult your doctor about operating this machine while taking prescription medications.
-  Do not allow others to ride on the tractor with an operator. Riders are subject to injury such as being struck by foreign objects or being thrown off. Riders obstruct the operator's view resulting in unsafe operation. **Never allow anyone to ride on the implement!**
-  Before you operate the rear blade, check over all pins, bolts and connections to be sure all are securely in place. Replace any damaged or worn parts immediately.
-  Do not allow anyone who is not familiar with the safety rules and operation instructions to use this rear blade.
-  Never allow children to operate or be around equipment.
-  Use stabilizer bars, adjustable sway chains, or sway blocks on your tractor lift arms to keep the rear blade from swinging side to side. Adjust as tightly as practical for best performance.

SAFETY INSTRUCTIONS (continued)

-  Keep alert and watch the front as well as the rear when working with the implement.
-  When maneuvering close to buildings or passing through narrow areas, be sure to allow sufficient clearance for the implement.
-  Do not operate close to ditches or creeks. Slow down when operating over rough ground.
-  Always be sure the implement is in the fully raised position when in transport.
-  When adjusting the angle of the moldboard assembly, be sure that your feet are never under the rear blade.
-  Use extreme caution when backfilling deep holes or trenches.
-  Be careful to avoid catching the rear blade on stumps or other immovable objects.
-  Use care when working on slopes.
-  Avoid excessive speed during operation.
-  Make adjustments only when the implement is attached to the tractor.
-  When using the rear blade in a reverse position, use extra care. **Do not ram rear blade** into piles of dirt. Tractor lift arms and the rear blade are not built to take high impact loads in this position. **Ramming** backwards can also dislodge operator from seat and/or tractor controls, resulting in possible serious injury or death.
-  Always ease the tractor into the load. It may be necessary to reposition and take less “bite” on the material to move it safely.
-  Watch for and avoid hidden obstructions, i.e., buried pipes, rocks, concrete piers, uneven concrete slabs, stumps, etc., when operating.

SAFETY SIGNS

This SAFETY SIGN is located on the frame of your rear blade. Obey ALL Safety Warnings.

NOTE:
If Safety Sign is missing or damaged, replace immediately.



CAUTION

Failure to follow safe operating practices can cause property damage and bodily injury.



1. Use tractor hitch sway bars to prevent side sway.
2. Never ram blade into dirt or snow piles with blade in reverse position. Ramming backwards can unseat operator from tractor or controls.
3. Keep fingers away from adjusting holes.
4. Reposition blade with tractor on level ground only to prevent blade from swinging or sliding into operator.
5. Watch for and avoid obstructions. Never hit mounds or ridges (especially ice and snow) at high speed as obstructions may be hidden.
6. Read other safety precautions in owner's manual.

Part #101033

INSTRUCTIONS

TRACTOR REQUIREMENTS AND PREPARATION

The Model EB-6-3 and EB-7-3 Rear Blades will fit most Category I tractors equipped with a standard 3-point hitch.

The Model EB-6-3 and EB-7-3 Rear Blades are economy blades for use on Category I tractors up to 35 horsepower in size. For use on larger tractors, extra care is required and it is strongly suggested that purchasing a heavier rear blade be considered.

Check the tractor's 3-point hydraulic lift system. It should operate up and down smoothly and hold its position when set. Refer to your tractor owner's manual or dealer for any adjustments necessary to put the 3-point hydraulic lift system in good working order. (I&T shop manuals will list most specifications and adjustment instructions – available from most farm equipment dealers.)

Tractor should be equipped with stabilizer bars, adjustable sway chains, or sway blocks to keep the implement from swinging side to side.

Smaller size tractors may need front counter weights to counter-balance the weight of the implement.

It is recommended that the tractor be equipped with a Rollover Protection System (ROPS) and a seat belt that is used.



Be sure your tractor is in good condition and properly equipped with counter weights. Read all the safety precautions and make sure all tractor operators are familiar with the safety rules of tractor operation.

ASSEMBLY AND MOUNTING

It is suggested that you mount the main frame on the 3-point hitch of your tractor before assembling the blade as follows:

1. Lower the 3-point hitch on your tractor to facilitate mounting of the main frame of the blade to the tractor.
2. Insert the lift arm pins on the main frame into the ball sockets in the lift arms of the tractor 3-point hitch. Pin in place with linch pins (not furnished).
3. Attach the mast of the main frame to the tractor by installing the tractor center (or top) link with a top link pin (not furnished). Pin in place with a linch pin (not furnished).

The main frame of the blade is now installed on the tractor. You are ready to proceed with assembling the moldboard and cutting edge assembly to the main frame as follows:

1. Remove the 1/2" –13 x 1 1/2" hex head bolts fastened in the blade mounting brackets on the spindle assembly.
2. Position the moldboard assembly in front of the spindle assembly with the lower moldboard mounting bracket resting on top of the moldboard reinforcing strip. Secure in place with the 1/2" –13 x 1 1/2" hex head bolts. (**NOTE:** The moldboard assembly may be positioned in the center or offset, 12" to the right, or 12" to the left, according to the setting desired.)
3. Tighten all bolts securely.

Once the moldboard assembly is mounted to the 3 pt. hitch frame, turn the moldboard assembly to your desired operating angle and insert the angle adjustment shift pin.

NOTE: Always use the tractor anti-sway bars, blocks, or chains to prevent blade side-sway. This is a must when using the blade in a reverse position.

Your Rear Mounted Blade is now assembled and mounted on your tractor. It is ready to go to work for you.

GENERAL SAFETY

The designed and tested safety of this machine depends on it being operated within the limitations as explained in this manual. Be familiar with and follow all safety rules in the manual, on the blade and on the tractor.

The safe operation of this machine is the responsibility of the owner/operator. The operator should be familiar with the blade and tractor and all safety practices before starting operation. Read the safety rules.

Never let anyone stand between the rear of the tractor and the rear blade while the tractor is backing up to connect to the blade. Always stand to the side until tractor has come to a complete stop and the brakes set or the tractor shift placed in "PARK".



**SAFETY . . .
YOU CAN LIVE WITH IT!**

INSTRUCTIONS (continued)

OPERATION

Check for ditches, stumps, holes, or other obstacles that could upset tractor or damage blade. Always turn off tractor engine, set parking brake, lower blade to ground before dismounting tractor.

Attaching the blade to the tractor increases the overall length of the working unit. Allow additional clearance for the blade to swing when turning.

Your rear blade can be used for all types of blade work, including casting, side ditching, leveling, terracing, grading, bulldozing, and snow removal.

1. **CASTING:** The blade should be angled horizontally – only enough to allow the material to slide along it easily. The vertical angle (tilt) of the blade must be set to suit conditions. This is controlled by the lift arm leveling assembly (turnbuckle) on the tractor 3-point hitch.

2. **SIDE DITCHING:** The horizontal angle should be at its sharpest. This is obtained by removing the shift pin and turning the moldboard so that the last hole in the circle plate is in line with the shift pin hole, then replace the shift pin. It is suggested that the blade be set in an offset position and then use the shorter blade side to be the cutting side. This reduces the load movement on the end of the blade.

The vertical angle of the blade (tilt) is adjusted by means of the adjustable turnbuckles on the tractor 3-point hitch. For the sharpest angle, lengthen the center link on the tractor as far as possible. Also, lower the adjustable leveling turnbuckle as far as possible.

3. **LEVELING:** The blade should be straight across, i.e., 90° to the line of travel of the tractor, in other words 0° horizontal angle.

There should be 0° vertical angle, i.e., the lift arms on the tractor 3-point hitch should be parallel to the ground.

The cutting pitch of the blade should be the opposite of that used in side ditching and casting, with the cutting edge behind the top edge of the moldboard. This adjustment is made with tractor center link.

4. **TERRACING:** Use a combination of ditching, casting, and leveling. The first cut is into the hillside in the ditching position. Continue until the terrace is at proper depth, then switch to the casting position until the terrace width is established. It may be necessary to use the leveling position to complete the job.

5. **BULLDOZING:** When bulldozing, the blade is in reverse position. Depending on the job, the casting, side ditching, or leveling position may be used. Snow removal can also be done with the blade in this position (blade in reverse, cutting edge away from tractor).

(**NOTE:** Most blades are damaged in this position – use extra care – DO NOT RAM blade into snow or dirt piles!)



When using the rear blade in a reverse position use extra care - DO NOT RAM REAR BLADE into dirt piles! Tractor lift arms and the rear blade are not built to take high impact loads in this position. RAMMING backwards can also dislodge operator from seat and/or tractor controls, resulting in possible serious injury or death.

6. **GRADING:** Grading is a combination of casting, side ditching, and leveling. Snow removal can also be done with the blade in this position (cutting edge toward the tractor).

These suggestions are generalities; best results will be obtained after some experience.

NOTE: Do not load either end of the blade heavily. Try to balance the load on both ends of the blade.



Watch for and avoid hidden obstructions, i.e., buried pipes, rocks, concrete piers, or uneven slabs of concrete, when operating, or blade damage may occur. This is especially true when removing snow.

MAINTENANCE

- Periodically check all bolts and tighten where necessary.
- Check the shift pin for excessive wear and replace if necessary.
- Repaint parts where paint is worn or scratched to prevent rust.
- Always store blade in a clean, dry location away from children and livestock.

TROUBLESHOOTING GUIDE

PROBLEM	POSSIBLE CAUSE	POSSIBLE REMEDY
Blade will not penetrate soil.	1. Cutting edge dull.	Replace cutting edge.
	2. Blade set too straight.	Increase 3 pt. hitch toplink length.
	3. Soil too hard.	Loosen soil with scarifiers or disk. Wait for rain.
Moldboard digging in too much.	1. Blade pitch excessive.	Adjust toplink (shorten).
	2. Soft ground.	Install skid shoes. Wait for dryer soil.
3 Pt. hitch frame bent.	1. Hitting hidden objects in backfill position or ramming backwards at high speed into hard piles of soil.	Use slow speed when in unknown soil conditions. Always backfill at slow speed.
	2. Using too large of tractor.	Preferably use tractor of recommended horsepower. Slow down and use extra care.
Bent moldboard.	1. Small curve is normal from welding.	Can be removed, but will not effect blade operation.
	2. Hitting hidden objects.	Know soil conditions. Use slow speed when soil conditions unknown.
	3. Using too large of tractor or one that is heavily weighted and has four wheel drive.	Preferably use tractor of recommended horsepower. Slow down and use extra care.
Unable to hold level grade.	1. Tractor draft control lifting blade.	Set tractor draft control.
	2. Soil too hard.	Use scarifiers.

3 PT. REAR MOUNTED BLADE

EXPLODED PARTS VIEW FOR EB-6-3 AND EB-7-3

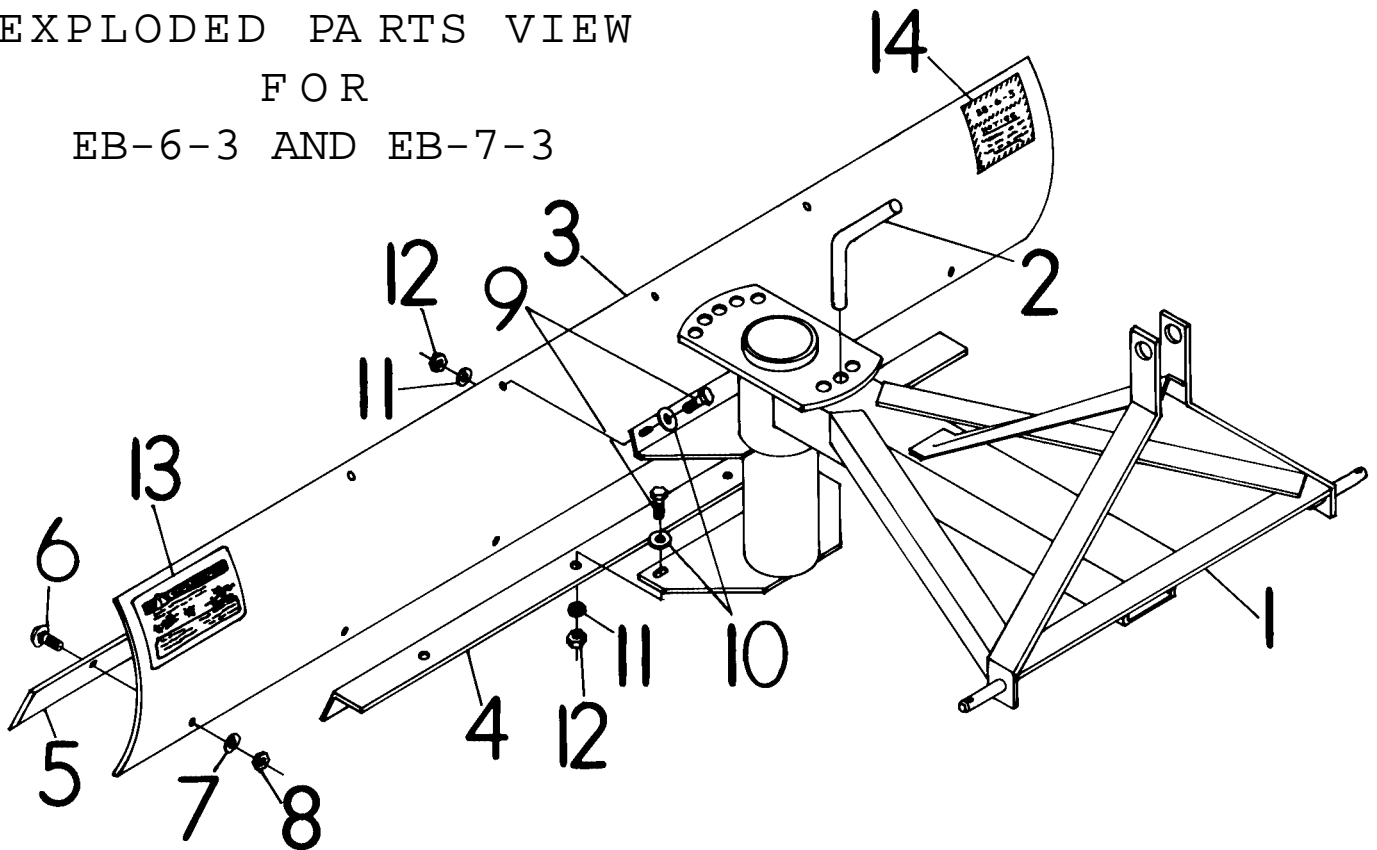

R E P A I R P A R T S L I S T

REF. NO.	PART NO.	DESCRIPTION	NO. REQ'D.
1	320007	3 Pt. Mount	1
2	320023	Shift Pin	1
3	320026	Moldboard - EB-6	1
	322010	Moldboard - EB-7	1
4	320027	Lower Shift Bar - EB-6	1
	322011	Lower Shift Bar - EB-7	1
5	320028	Cutting Edge - EB-6	1
	322012	Cutting Edge - EB-7	1
6	2503103	Bolt, $\frac{3}{8}$ " - 16NC x 1 1/2" Carriage Head	Var.
7	2502008	Washer, $\frac{3}{8}$ " Springlock	Var.
8	2500004	Nut, $\frac{3}{8}$ " - 16NC Full Hex	Var.
3-8	320024	Moldboard Assembly EB-6	1
	322008	Moldboard Assembly EB-7	1
9	2503004	Bolt, $\frac{1}{2}$ " - 13NC x 1 1/2" Hex Head	4
10	2501003	Washer $\frac{1}{2}$ " Flat	4
11	2502002	Washer $\frac{1}{2}$ " Springlock	4
12	2500003	Nut, $\frac{1}{2}$ " - 13NC Full Hex	4
13	101033	Caution Decal	1
14	101050	Warranty Notice (H.P. Rating) EB-6	1
	101051	Warranty Notice (H.P. Rating) EB-7	1

SKID SHOE (Optional)

For a complete set (pair) of SK-4 Skid Shoes order #320035

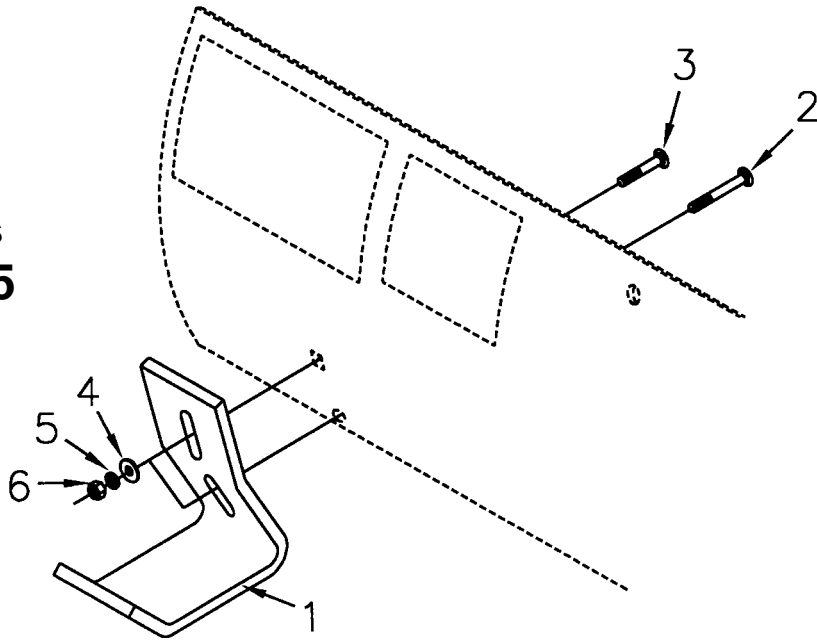

SK-4 SKID SHOE PARTS LIST

Ref. No.	Part No.	Description	No. Req'd.
1	320037	Skid Shoe Plate	2
2	2503189	Bolt 3/8"-16NC x 2" Carriage Head	2
3	2503103	Bolt 3/8"-16NC x 1 1/2" Carriage Head	2
4	2501004	Washer 3/8" Flat	4
5	2502008	Washer 3/8" Springlock	4
6	2500004	Nut 3/8"-16NC Full Hex	4

Skid shoes allow the blade to operate at a set height above ground level. This is useful when removing snow on a gravel drive, as the blade can move the snow without scraping a lot of stones over into the grass.

Adjust the skid shoes to the desired operating height by moving the shoes up or down with the slotted bolt connection to the back of the moldboard. Tighten these bolts before using the blade.

NOTE: Do not drop the blade down hard on the skid shoes – the impact may change the skid shoe height setting.

LIMITED WARRANTY

Worksaver warrants its implements, parts and accessories to be free from defects in materials and workmanship for a period of six (6) months from date of purchase for non-commercial, state, and municipalities'. Use ninety (90) days for commercial use from date of retail sale.

SPECIAL WARRANTY PROVISION

Warranty shall only apply to defects in material and workmanship. In no case shall the manufacturer be liable to the purchaser for the bending or breakage of any part of the blade by abuse or misuse, such as striking hidden objects, grubbing stumps, or using tractors larger than the blades maximum horsepower rating whether intentional or unintentional.

DISCLAIMER OF IMPLIED WARRANTIES & CONSEQUENTIAL DAMAGES

Worksaver's obligation under this warranty, to the extent allowed by law, is in lieu of all warranties, implied or expressed, including implied warranties of merchantability and fitness for a particular purpose and any liability for incidental and consequential damages with respect to the sale or use of the items warranted. Such incidental and consequential damages shall include but not be limited to: transportation charges other than normal freight charges; cost of installation other than cost approved by Worksaver; duty; taxes; charges for normal service or adjustments; loss of crops or any other loss of income; rental of substitute equipment, expenses due to loss, damage, detention or delay in the delivery of equipment or parts resulting from acts beyond the control of Worksaver.

THIS WARRANTY SHALL NOT APPLY:

1. If the unit has been subjected to misapplication, abuse, misuse, negligence, fire or other accident.
2. If parts not made or supplied by Worksaver have been used in connection with the unit, if, in sole judgement of Worksaver such use affects its performance, stability, or reliability.
3. If the unit has been altered or repaired outside of an authorized Worksaver dealership in a manner which, in the sole judgement of Worksaver affects its performance, stability or reliability.
4. To expendable or wear items such as skid shoes, cutting edges, and other items that in the company's sole judgement is a wear item.

NO EMPLOYEE OR REPRESENTATIVE OF WORKSAVER IS AUTHORIZED TO CHANGE THIS WARRANTY IN ANY WAY OR GRANT ANY OTHER WARRANTY UNLESS SUCH CHANGE IS MADE IN WRITING AND SIGNED BY WORKSAVER'S SERVICE MANAGER, POST OFFICE BOX 100, LITCHFIELD, ILLINOIS 62056-0100.

⚠ SAFETY PRECAUTIONS ⚠

**MOST ACCIDENTS OCCUR BECAUSE OF NEGLIGENCE OR CARELESSNESS.
AVOID NEEDLESS ACCIDENTS BY FOLLOWING ALL OF THE SAFETY PRECAUTIONS LISTED BELOW.**

- Machinery should be operated only by those who are responsible and are authorized to do so.
- Stop the engine, lower all equipment, lock the brakes, and remove the ignition key before dismounting from the tractor.
- Never stand between tractor and implement while tractor is being backed to hitch.
- Loose fitting clothing should not be worn, to avoid catching on various parts.
- Detach implement in area where children normally do not play.
- When performing adjustments or maintenance on an implement, first lower it to the ground or block it securely at a workable height.
- Only a qualified operator should be permitted on tractor when in operation; no riders allowed.
- Make certain everyone is in the clear before starting tractor or raising or lowering equipment.
- Operate the tractor and implement only while seated in the driver's seat.
- Reduce speed when transporting mounted implements to avoid bouncing and momentary loss of steering control.
- A heavy load can cause instability of the tractor. Use extreme care during road travel. Slow down on turns and watch out for bumps. Tractor may need front counterweights to counter-balance the weight of the implement.
- Reduce speed on hillsides or curves so there is no danger of tipping.
- Avoid driving too close to the edge of ditches or creeks.
- Do not transport implement on public roads without reflectors and slow moving vehicle emblem in daylight and with approved warning lights at night and other periods of poor visibility.
- Due to the width of some implements, use extra caution on highways, farm roads, and when approaching gates.
- Always be sure the implement is in the proper position for transport.
- Keep alert and watch the front as well as the rear when working with the implement.

OWNER'S/ OPERATOR'S MANUAL

**MODEL NO.'s
EB-6-3
EB-7-3**

**WHEN ORDERING
REPAIR PARTS,
ALWAYS GIVE
THE FOLLOWING
INFORMATION:**

1. PART NUMBER
2. PART DESCRIPTION
3. MODEL NUMBER
4. NAME OF ITEM

JANUARY 2001

**MAKE EVERY DAY
A HOLIDAY
FROM ACCIDENTS**

3 PT. REAR MOUNTED BLADE

For Cat. I 3 Pt. Hitch Tractors
from 17 to 35 H.P.

STATEMENT OF POLICY

It is the policy of Worksaver, Inc. to improve its products where it is possible and practical to do so. Worksaver, Inc. reserves the right to make changes or improvements in design and construction at any time, without incurring the obligation to make these changes on previously manufactured units.

WORKSAVER, INC.

**P.O. BOX 100 LITCHFIELD, IL 62056-0100 (217) 324-5973
WEB: <http://www.worksaver.com> E-MAIL: sales@worksaver.com**